

# MiniMax Series *by*

Version 2.1

Release Date: March 2018

Serial: VT18032 and on



# Vrisimo

FLAIL MOWERS & SHREDDERS

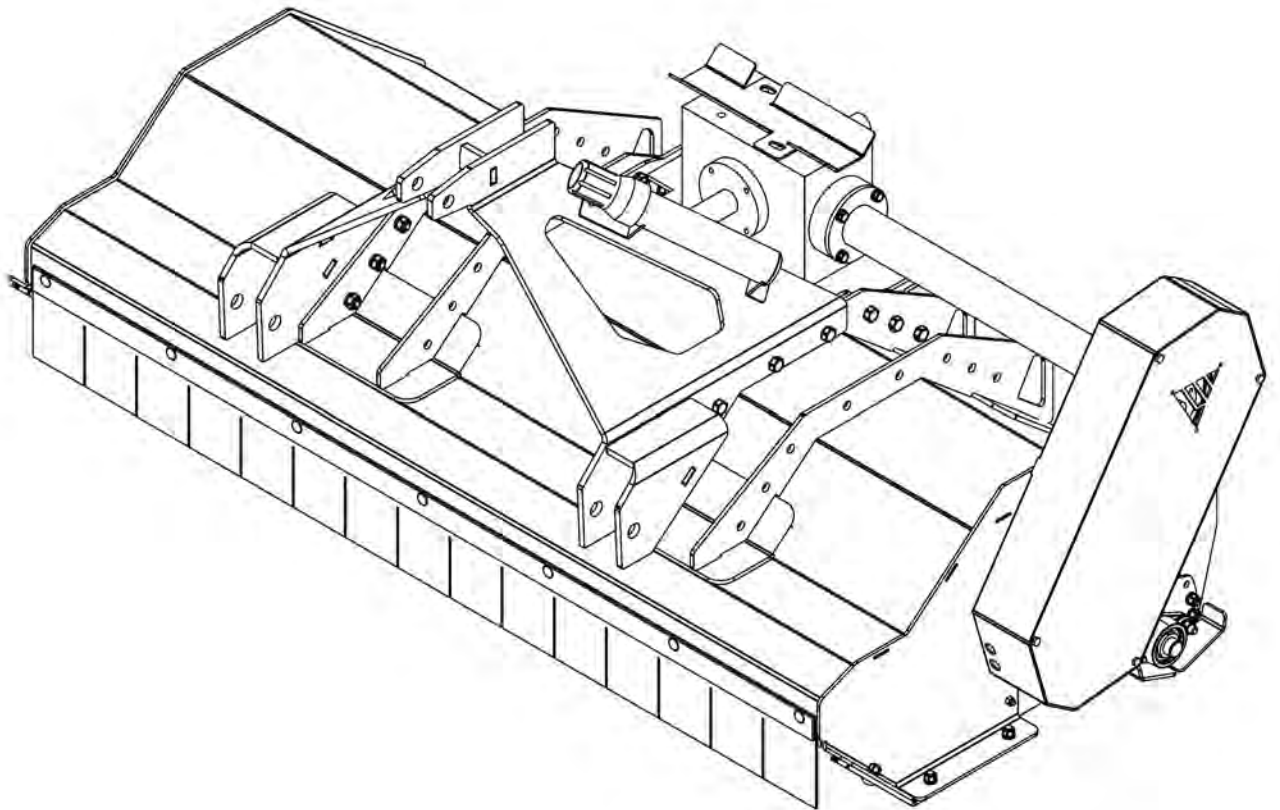

MiniMax OWNER'S MANUAL

PO Box 220 | 2507 Tully Rd. | Hughson, CA 95326 USA |



**VALLEY TOOL**  
MANUFACTURING COMPANY

800-426-5615

[www.Valleytoolmfg.com](http://www.Valleytoolmfg.com)



## Delivery Report Form

Prior to acceptance of the equipment, thoroughly check and mark off the items outlined in the delivery checklist below with your sales representative. Make sure you fully understand the operation, adjustment and safety rules as outlined in the operator's manual. The sales representative is responsible for going over this form with the owner and operator of this attachment. This form also serves as your warranty registration. Fax to 209-882-9001.

### Customer Information

Last Name		Street Address	
City	State	Zip	

### Attachment Information

Model	Serial Number
-------	---------------

### Dealer Information

Company Name		Sales Rep. Name	
Company Street Address	City	State	Zip

- Buyer is shown all grease fittings and proper gear oil height.
- Oil in Gearbox checked for proper level and weight.
- All bolts checked for tightness.
- All hitch pins and retainer bolts in place.
- All knives and linkages in place.
- All shields in place.
- Belts checked for proper adjustment.
- PTO shaft checked for proper length.
- Procedures for attaching mower/shredder to tractor demonstrated to end user.
- Starting procedures explained to end user.
- Operation guidelines as outlined in owner's manual explained to end user.
- Adjustment of cutting height, belts and mower height explained to end user.
- Replacement of mower/shredder knives explained to owner.
- Lubrication points shown to end user.
- ALL safety precautions thoroughly read and understood.

**The signatures below indicate that both the sales representative and the end user have gone over the above checklist and all topics have been covered thoroughly.**

Buyer Signature \_\_\_\_\_ Date \_\_\_\_\_  
 Dealer Signature \_\_\_\_\_ Date \_\_\_\_\_



---

# Table of Contents

## **Introduction**

Thank You .....	1
Warranty Information .....	2

## **Safety**

Operational Safety .....	3
Maintenance Safety .....	4

## **Basic Operation**

Attaching to Tractor/Starting Procedure .....	5
Running Your Mower .....	6

## **Adjustments and Maintenance**

Cutting Height and Belt Adjustment .....	7
Replacing Knives .....	7
Cleaning Mower .....	7
Lubrication .....	9
Transport, Removal and Storage .....	9
Frequently Asked Questions .....	11

## **Parts Catalog**

Pulley/Top Shaft Assembly .....	15
Back Roller/Cutter Drum Assembly .....	16
PTO Shaft Assembly .....	17
Gearbox Assembly .....	18
Decals .....	19
General Parts .....	22
Torque Specifications .....	23
Notes .....	24

# Thank You

---

Dear Customer,

Thank you for purchasing a Vrisimo attachment. This manual has been prepared to acquaint you with the operation, adjustment and maintenance of your new attachment. It was carefully designed and manufactured under the highest industrial standards to give you years of dependable service. Read this manual carefully and fully understand the operation of the machine before attempting to operate it. Each section has been clearly identified so you can find the information you need. Vrisimo Flail Mowers and Shredders reserves the right to make changes in design and specifications, and/or to make additions to or improvements in its products without any obligation upon itself to install them on its products previously manufactured. If at any time you require additional information, consult your authorized dealer or the customer service department.

## Attention

The safety of the operator was one of the primary concerns of Vrisimo Flail Mowers & Shredders when designing this attachment. Shielding, simple adjustments and other safety features were built into this attachment whenever possible. You can make your home, orchard or farm a safer place by observing the precautions noted in this manual. Be sure you and the people working for you read and understand them. All machinery should be operated only by responsible persons who have been trained to operate them in a safe manner and have read and understand the operating precautions and instructions fully.

## Important to Purchaser

### Customer Ownership Registration

Prior to acceptance of the equipment, thoroughly check off the pre-delivery checklist with sales representative. Be sure you fully understand operation, adjustment and safety rules as outlined in this manual



*Vrisimo Flail Mowers & Shredders* is solely owned by Valley Tool and Manufacturing.

Have industrial applications? Own a skid steer or mini excavator? for our full line of industrial applications.

Visit [www.Vrisimo.com](http://www.Vrisimo.com)



PO Box 220 | 2507 Tully Rd. | Hughson, CA 95326 USA |

800-426-5615

[www.Valleytoolmfg.com](http://www.Valleytoolmfg.com)

---

## **Warranty**

Vrisimo Equipment guarantees the Vrisimo Flail Mower to be free from defect in material and workmanship for a period of one year dating from delivery to the original user. The obligation under this warranty, statutory or otherwise, is limited to the replacement and/or repair at your authorized Vrisimo dealer of choice part or parts as shall appear to us, upon inspection, to have been defective in material or workmanship and not altered in any way by the customer or other parties.

This warranty shall not apply to vendor warranted PTO items such as bearings, belts, PTO shafts and gearboxes or other parts not manufactured by Vrisimo Equipment. Such being subject to the warranty of their respective manufacturers.

No expressed, implied or statutory warranty other than herein set forth is made or authorized to be made by us. Vrisimo Equipment shall not be liable for consequential damages of any kind, including but not limited to: consequential labor costs or transportation charges in connection with the replacement or repair of defective parts, lost time or expense which may have accrued because of said defects.

Vrisimo reserves the right to make changes in its products at any time and without prior notice. When such changes are made, neither Vrisimo Equipment nor its dealers assume any obligation to make these changes in products previously manufactured.

# Safety

---

## Operational Safety

- **Before operating this machinery, read the owner's manual thoroughly.**
- Do NOT operate this machine without proper training. It is the owners responsibility to ensure all Operators are properly trained in the appropriate language.
- Use OSHA approved eye, ear and head protection to protect the Operator from flying debris and noise.
- Avoid wearing loose clothing as it can inadvertently be drawn into moving parts.
- Never use drugs or alcohol before or during operation of this machine.
- Only operate this machine when it is in good working order on an appropriate power unit that is in good working order, and with all guards and safety devices in place and functioning.
- Be aware of the machine's weight and its effect on the stability of the power unit.
- Use flashing warning lights when operating on highways, except when prohibited by law.
- Always inspect area to be worked to ensure that the jobsite is free from obstacles and debris that could injure the operator or damage the machine. Operate at a safe speed (typically 0-5 mph) in consideration of the local terrain, moving slower when operating on or near slope, ditches or drop-offs.
- Avoid running the machine along the ground in rocky areas as this could create dangerous discharge.
- Never allow children or other persons to ride on this mower.
- Keep bystanders and children clear of the work area during operation as debris can be discharged in a dangerous manner. The minimum safe distance is 100 ft.
- Be aware that this machine may be wider than the power unit, and caution should be used to avoid clipping or running over trees, signs or posts that may be in the way of the machine.
- Avoid operation that would allow hydraulic lines to be pinched or severed. In the event of a hydraulic leak, hydraulic fluid may have sufficient force to penetrate skin, which requires immediate medical attention.
- Do not turn so sharp or lift the mower so high that the driveline produces a sever knocking as this will cause the accelerated wear of drive train components. The drum should not be rotating when the deck is lifted.
- Be aware of the risks to equipment and grass fires. To mitigate those risks:
  - \* Do not smoke or have open flame in the work area.
  - \* Do not operate in areas that have been freshly burned or are still burning.
  - \* Do not allow clippings/debris to collect near hydraulic components or bearings.
  - \* Avoid areas with high fire risk: dry grass, brush or trees.
- Operation of this machine should be stopped immediately if the Operator's vision becomes obscured by the discharge of debris and dust. Also avoid operating this machine in unusually foggy or dusty conditions or at night.



- 
- Keep away from the machine until all the energy has dissipated. This includes the complete stopping of the drum's rotation as well as the dissipation of pressure in the hydraulic lines.
  - In the event that a failure does occur during operation or if the machine begins to produce excessive noise or vibration, shut the machine down immediately and repair before any continued use.
  - Never leave the machine unattended unless it is in the storage or transport position.
  - **In addition to the design and configuration of equipment, hazard control and accident prevention are dependent upon the awareness, concern and prudence and requires suitable training of personnel involved in the operation, transport, maintenance and storage of equipment.**

## **Maintenance Safety**

- **Before performing maintenance on this machine, read the owner's manual thoroughly.**
- Maintenance should only be performed by properly trained individuals. It is the Owner's responsibility to ensure all individuals involved in maintaining the machine are properly trained in the appropriate language.
- Be sure to inspect all safety devices before each use. If safety devices are worn in such a way that they can no longer properly perform their guarding function, contact your nearest Vrisimo dealer for replacements.
- Maintain all safety decals and make sure they are visible to the operator. If decals are worn, contact your nearest Vrisimo dealer for replacements.
- Replace cracked or broken blades with new ones. Don not attempt to weld damaged blades . This can cause damage that could result in the blade being thrown from the shredder.
- Wear gloves and eye protection and exercise care when handling blades as they can be sharp. Also be alert to worn or damaged surfaces that could have sharp edges.
- Disengage PTO, shut off engine and allow all movement to stop before leaving the operator's position to adjust, lubricate, clean, or unclog the machine. Do not try to uncouple hydraulic hoses unless the pressure has adequately dissipated.
- Before working on or underneath the machine, place blocks on both sides (front and back) of power unit's tires or treads and under each end of the attachment to prevent accidental lowering of the machine. Also, remove the ignition key from the power unit and allow all movement to stop before beginning work.

# Basic Operation

## Attaching to the Power Unit

**Note:** When you ordered your Vrisimo Attachment, details about your Power Unit were provided to custom match your Attachment to your Power Unit. While Vrisimo Attachments can be attached to a variety of different tractors, your Attachment is specifically configured for your Power Unit and can not necessarily be placed on another Power Unit as is. Specifically, the mount category and gearbox/pulley were selected to mate to your Power Unit's hitch and optimize performance based on your PTO output, respectively. Your Attachment should only be connected to Power Units that share the same specifications as the information on the Power Unit you provided. Attachment instructions are for the most common configuration: 3-point hitch with a PTO output of 540 rpm.

The person that is attaching your Vrisimo product should be familiar with the attachment and removal of equipment from a 3-point hitch and be able to do so safely. Attachment should be performed on flat ground away from obstructions. During attachment, keep hands out of pinch points and away from the blades to avoid injury.

The tractor's drawbar should be placed to its shortest point, if there is still insufficient clearance then it should be removed. If your tractor has load and depth control, lock out control so it will not function but be in "free float."

- 1) Back the tractor up to the front of the machine so that the lift links are in line with the mower's hitch pins.
- 2) Shut off the engine and disengage the PTO. Block the tractor's wheels before placing yourself between the tractor and the attachment.
- 3) Attach the tractor's left and right lift links to the corresponding hitch pins of the attachment, secur

ing both connections with lynch pins.

- 4) Adjust the sway bars so that there is a minimum side slack and be sure the stabilizers are tight.
- 5) Attach the tractor's top link to the "A" frame of the attachment and adjust the top link to the approximate desired cutting height.
- 6) Attach the PTO to the tractor by pushing in on the quick disconnect pin. Remember, the tube end goes to the attachment and the bar end goes to the tractor.
- 7) With the attachment and PTO line connected check the drive shaft through the entire lifting range checking for binding, bottoming, uncoupling or attachment contact.

## Starting Procedure

The Operator should be properly trained on the use of your Vrisimo Attachment and wearing the appropriate safety gear. Do not start the Power Unit until the Attachment has been checked for proper assembly and installation. This includes the appropriate connection of the hitch and PTO connections as well as the proper functioning of all safety devices on both the Power Unit and the Attachment. Clear the work area of all bystanders and children:

- 1) Check that the attachment is in the down position and that the blades are not in contact with ground. Start engine and set throttle to idle. Never engage the PTO with the motor above idle speed.

- 2) With the motor at low RPM engage the PTO output.
- 3) Slowly bring the throttle up to 540 RPM. If the Attachment produces excessive noise or vibration, disengage the PTO and shut down the Power Unit immediately. Determine the cause of the problem and correct it before continuing with its operation.
- 4) Attachment is ready for operation.

## Running Your Attachment

- 1) Determine ground speed based on terrain and material being cut. This will typically fall within the 0-5 mph range.
- 2) Position skid shoes between 1/2-3" off the ground; skid shoes are not meant to run on the ground.
- 3) The mower and skid shoes should be level with the ground, the height of the mower can be adjusted with the back gauge roller which runs along the ground.
- 4) Adjust the sway bars so that there is a minimum side slack and be sure the stabilizers are tight.
- 5) Attach the tractor's top link to the "A" frame of the attachment and adjust the top link to the approximate desired cutting height.
- 6) Attach the PTO to the tractor by pushing in on the quick disconnect pin. Remember, the tube end goes to the attachment and the bar end goes to the tractor.
- 7) With the attachment and PTO line connected check the drive shaft through the entire lifting range checking for binding, bottoming, uncoupling or attachment contact.

## Shut Down Procedure

- 1) When work is completed, disengage the PTO drive and position it for storage or transport (See the "Transport, Removal and Storage" section for details on proper storage). Shut off Power Unit and set parking brake, wait for the attachment to stop rotating.
- 2) Visually inspect the PTO shaft, all the bearings and gearbox for excessive heat or leaks.

# Adjustments & Maintenance

---

**Note:** Before performing maintenance, ensure all motion has stopped and that the Power Unit is powered down with ignition key removed. Before working on or underneath the mower, place blocks on both sides of the Power Unit's tires and underneath both ends of the mower to prevent accidental lowering of the machine.

## Cut Height Adjustments

- 1) The cutting height of the mower can be adjusted from 0-4". Adjusting is done by shortening or lengthening the top-link. Under no circumstances should the knives contact the ground!
- 2) The entire weight of the mower should be on the back gauge roller. The skid shoes should be adjusted so there is 1/2"-3" clearance between them and the ground. The shoes are for added protection against tree roots, ridges or borders and are not designed to slide on the ground. Adjust the back gauge roller by removing the bolts from both sides and resetting it to the correct height.

## Wear Components

Wear components such as knives, belts and bearings may wear at different rates and so each should be inspected for wear independently.

- 1) Knives should be replaced when they are dull.
  - A) When individual knives, bolts or spacers become worn or damaged they must be replaced with hardware saved from your previous knife replacement. Replacing an individual station with new hardware could cause the cutter drum to run out of balance. When replacing hardware at all the

stations, some old hardware should be saved to replace future broken hardware.

B) Replacing the knives is done by disconnecting the mower and tipping it up on its front or rear end to gain access to the underside of the mower. Knives are individually removed by unbolting them from their connecting ears.

C) Once the knives have been removed, replace with new ones.

- 2) Decals that are no longer visible, damaged, or lost should also be replaced.
- 3) Skid shoes should be replaced as needed.
- 4) Belt adjustment is done by adjusting the tension arm.

## Cleaning Your Mower

- 1) Check for excessive grease in bearing areas on the pulley side of the mower. Make sure that grease is not allowed to get into the belt areas.
- 2) Clean any clippings from the gearbox areas, pulley areas and anywhere else that is prone to excessive heat where fire can start.
- 3) Clean the inside of the mower with a pressure washer. Make sure the inside of the mower is kept free from mud and compact grass. Keep in mind that mud built up on the cutter drum can cause imbalance.
- 4) Preserve damaged decals or replace them if they are unreadable. Decal kits can be obtained from your local Vrisimo dealer.

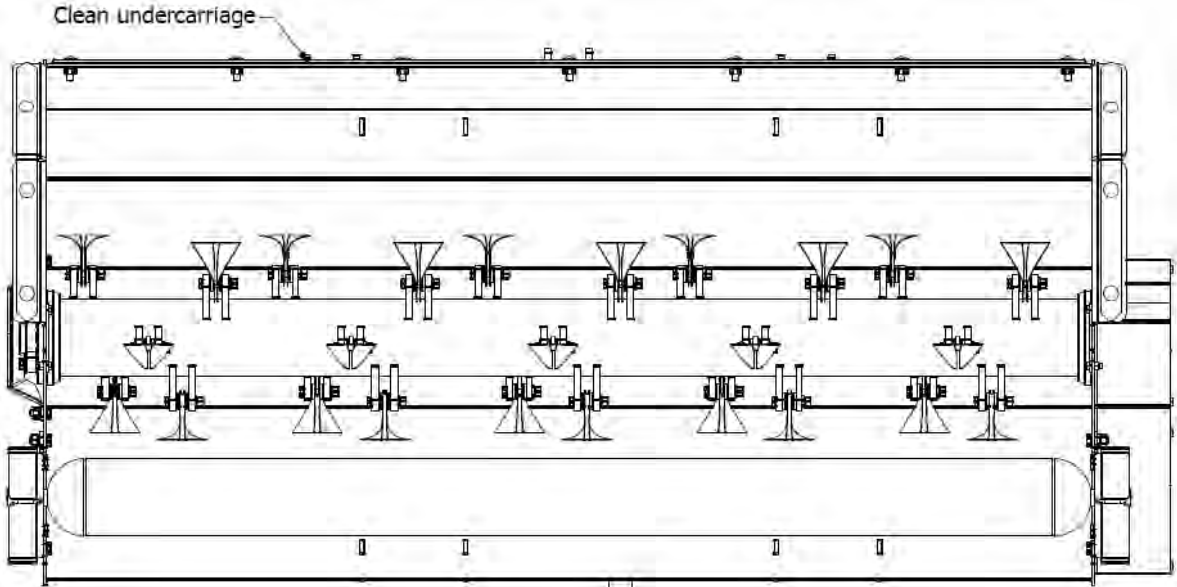
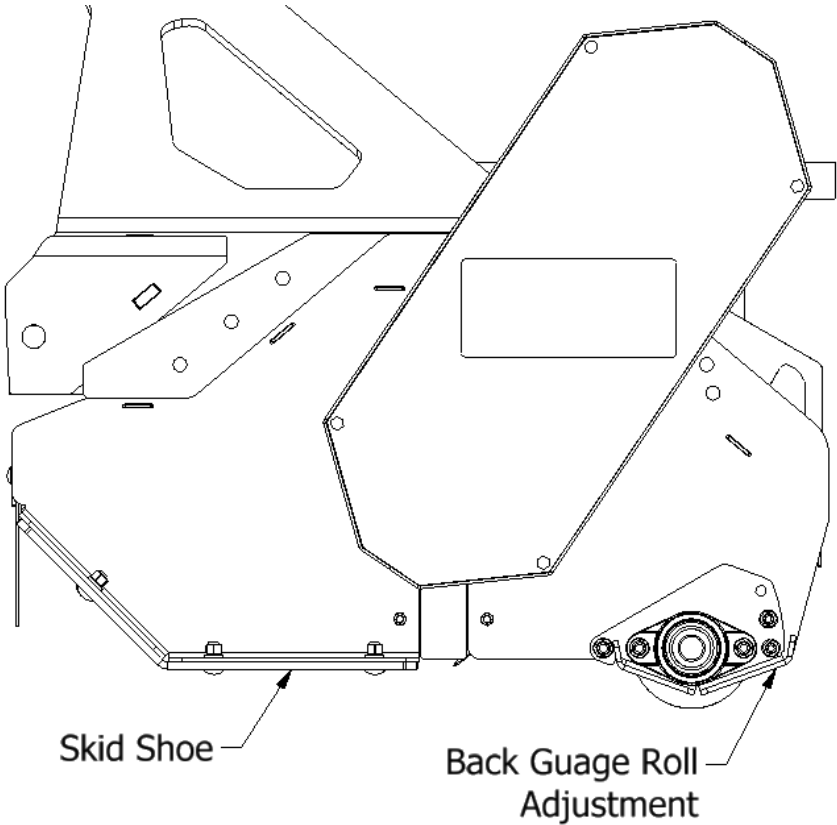

# Adjustments & Maintenance

## Lubrication

Location	Grease Type (NLGI)	Lubrication Interval (hours)	Quantity
Cutter Drum	2	10	As needed
Back Roller	2	10	As needed
Top Shaft	1	10	As needed
Driveline	2	10	As needed
Location	Oil Weight	Lubrication Interval (hours)	Quantity
Gearbox	SAE EP 90W	As Required	Fill to upper middle fitting

## Transport, Removal and Storage

Disengage PTO and shut off engine allowing all movement to stop before leaving the operators position to adjust, lubricate, clean or unclog the machine. Before working on or underneath the mower/ shredder, place blocks on both sides (front and rear) of tractor tires and under each end of the mower to prevent accidental lowering of the machine. Also remove the ignition key from the tractor and allow all movement to stop before beginning work.

### a) Transport on power unit

- 1) PTO must be disengaged, unit lifted off the ground

### b) Transport on Trailer

- 1) Chain down locations even if unit is still attached to tractor, secure PTO shaft

## c) Removal

- 1) Remove the adjustable top link from the tractor and mower
- 2) Disconnect the drive shaft from the tractor and mower
- 3) Remove the safety pins from the lower two link points. Remove the tractor arms from pin locations and re-insert the pins for storage.

## d) Storage

- 1) Put the drive shaft away in a clean, dry place
- 2) Clean the mower thoroughly (See the "Cleaning your Mower" section for details)
- 3) Relax belt tension (See the "Adjustments & Maintenance" section for details)
- 4) Lubricate the mower as recommended (See the "Lubrication" section for details)
- 5) Check oil level in gearbox and fill as required ( See the "Lubrication" section for details)
- 6) Check for worn parts and replace so you will be ready to mow when necessary. (see the "Adjustments & Maintenance" section)
- 7) Store in a clean, dry place

## Lubrication & Transport

### NOTE:

1. Remove grease from belts
2. Check for excessive grease on bearings
3. Clean Pulley Assembly of any debris after **every** use

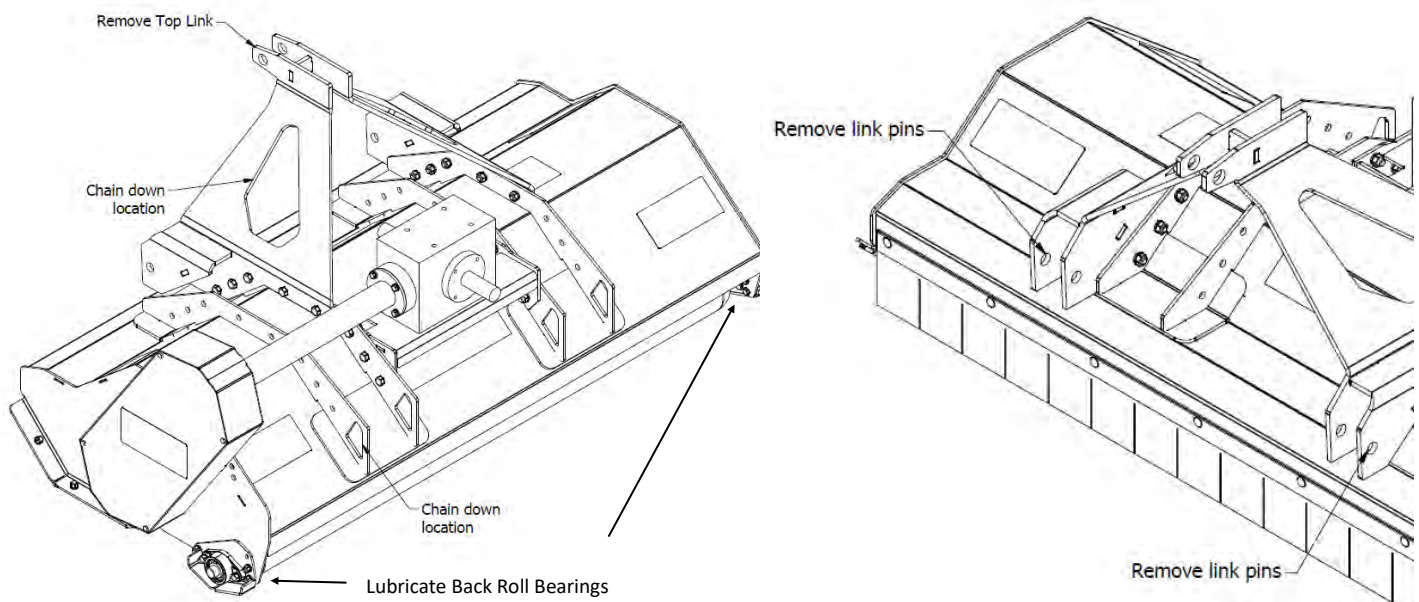
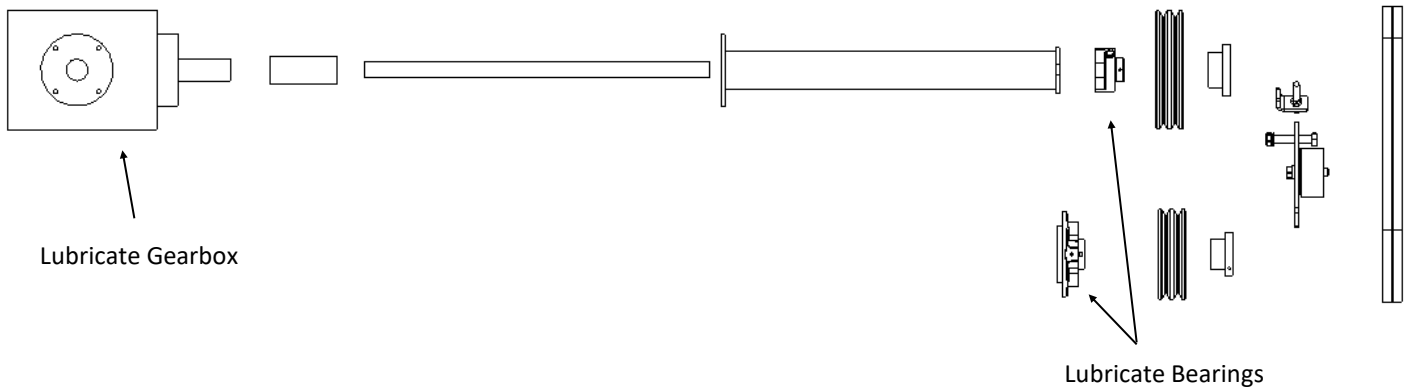

---

## Frequently Asked Questions

Q. Where do I find replacement parts?

R. First check your local tractor dealer and if they do not have parts, ask them to order from the Vrisimo factory.

Q. How often should I change my knives?

R. Replacing the cutting knives is entirely up to the owner. When the cut begins to be inconsistent or rough, consider replacing the knives. It is recommended to keep an extra set of knives on hand so that loss of work time is minimal.

Q. How often should I replace my belts?

R. If you are experiencing repeated slipping or breaking of belts, try adjusting the level of tension. If this does not remedy the problem, replace the belt. Consider having an extra belt on hand as well.

Q. Do I need to fill the gearbox with oil before I use the mower?

R. No, the gearbox comes full with oil. Use 90 weight oil when replacing.

Q. What do I do if my belts are wearing out too fast or burning up?

R. First check belt tension. Belts should have about 3/8" sway in them. Adjust tension accordingly. If this does not help, check the height of the grass you are mowing. If the grass is over 2 feet tall, you might have to adjust mower cutting height upwards and slow the speed of your travel to reduce belt slippage.

Q. My side skid shoes are wearing out too quickly. What do I do?

R. Operate the mower with the side skid shoes 0.5-3 inches off the ground. The side skid shoes are meant to collide only with mounds or objects in the field. The rear roller is the only part of the mower that should touch the ground during operation.

Q. How can I prevent my PTO shaft from coming off during operation?

R. Be careful! Make sure the shaft is slid all the way on and the safety pin is in the locked position.



## Frequently Asked Questions

- Q. When I am replacing gear oil, how much should I add?
- R. When replacing gear oil, fill from the Upper-middle fitting and when oil begins to come out, the box is full.

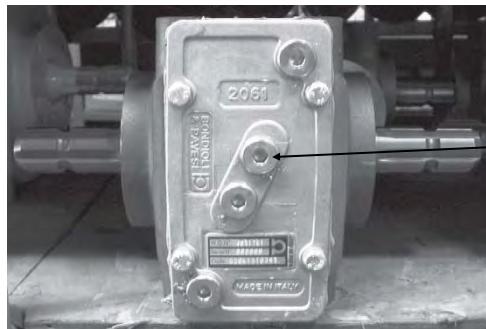

Upper-Middle Fitting

- Q. Are there any advantages to reversing cutter drum rotation?
- R. Whether or not reversing cutter drum is advantageous depends on the application. In most, normal rotation is a reverse rotation. This means that the cutter drum rotates in a fashion that would throw grass or clippings towards the tractor. The only advantage to reversing rotation would be if you are mowing in industrial applications such as along freeways, in places with large amounts of debris (i.e. plastic, metal, rocks), or using a front mount application. There are typically no advantages as far as the grade of cut you will get, but rather safety advantages as stated above.
- Q. How do I reverse cutter drum rotation?
- R. To reverse cutter drum rotation, simply un-mount the gearbox from its current position, remove the safety cover from the other shaft of the gearbox and rotate the gearbox so that the previously covered shaft is the one that will be driven by the PTO. Install the safety covers and it is ready to go. Note: Scoop knives must be rotated to accommodate for a reversed cutter drum rotation.
- Q. How do I replace my knives?
- R. Replacing the knives may vary depending on your model of mower/shredder. See the Adjustments/Maintenance section for detailed information.
- Q. When connecting my PTO shaft, can I put it on either way or should a specific side go to the mower/shredder and the other to the tractor?
- R. The PTO shafts for these mowers/shredders are side specific. The tube half of the PTO shaft goes to the mower/shredder and the bar half of the PTO shaft goes to the tractor.



# Parts Catalog

---

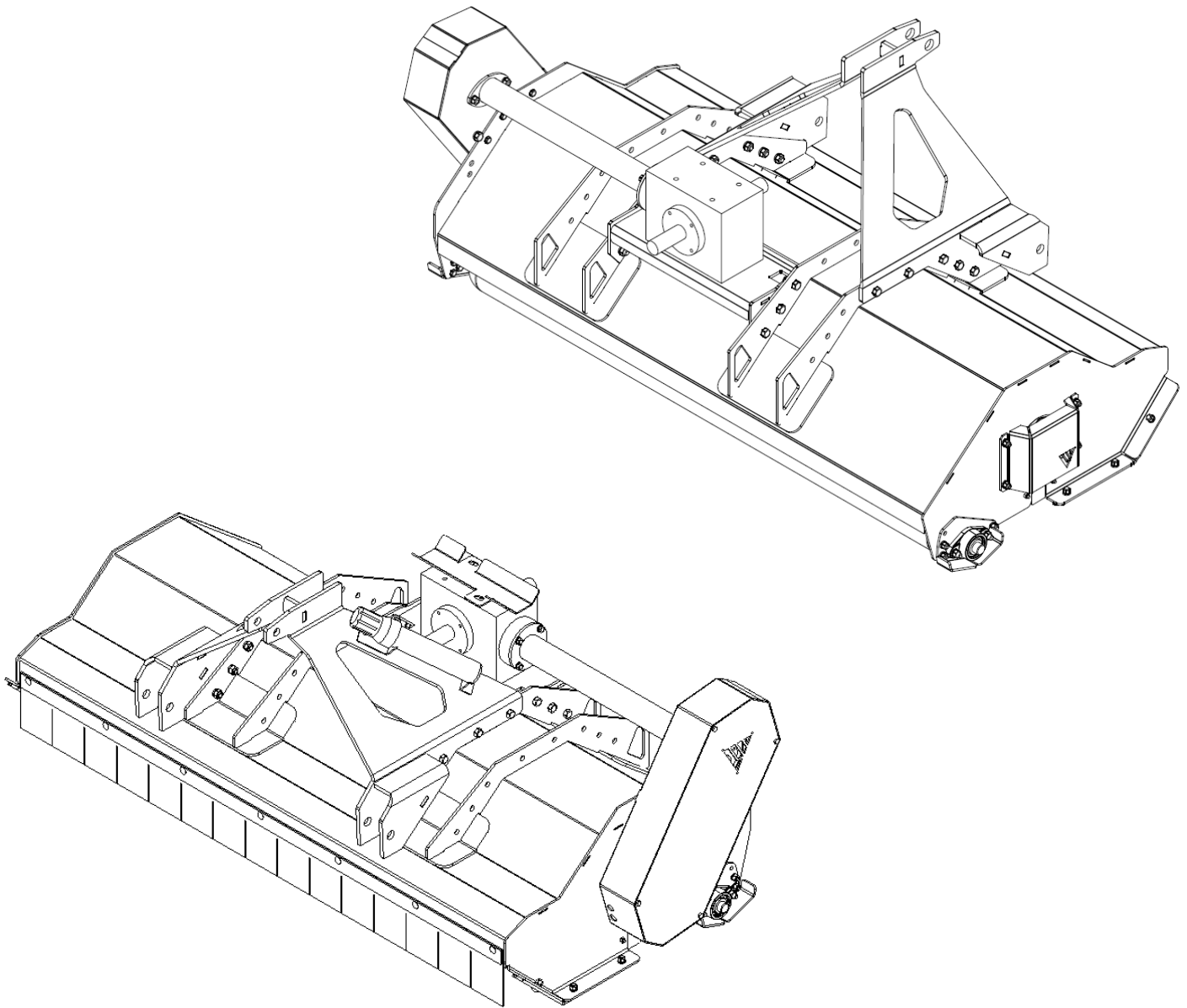

**MiniMax Series** *by*



**Vrisimo**

FLAIL MOWERS & SHREDDERS

**Parts Catalog**

**48 Inch**

**60 Inch**

**72 Inch**

# Pulley/Top Shaft Assembly

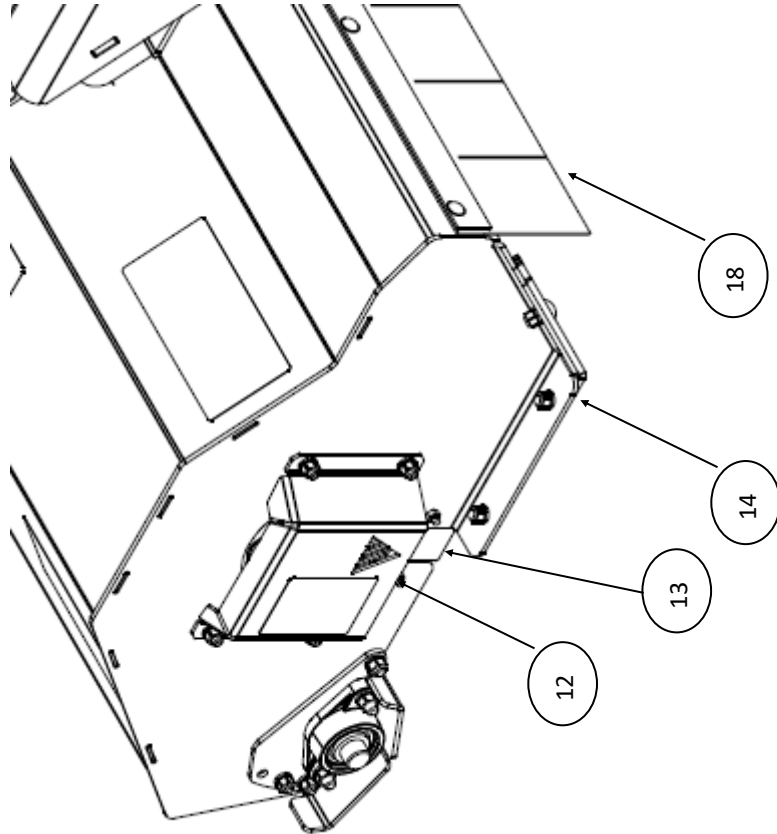
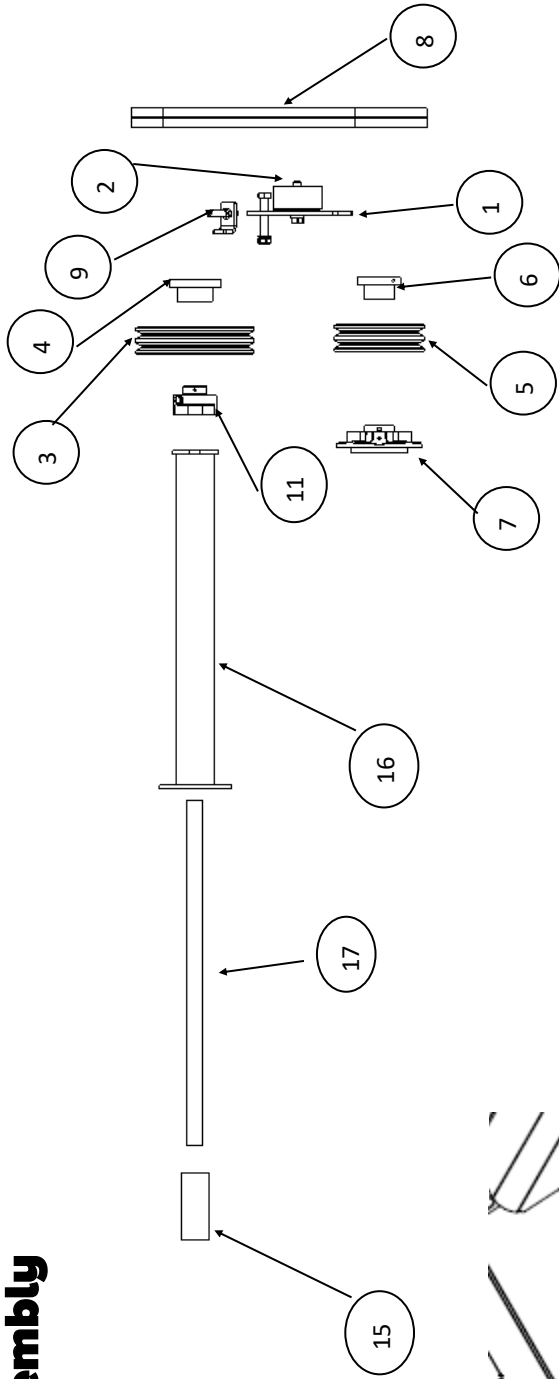

	Description	Qty	Model	P/N
1	Idler arm 3 pt	1	All	04171
2	Idle Pulley	1	All	04093
3	Driving Pulley	1	All	04087
4	Bushing Driver	1	All	04086
5	Driven Pulley	1	All	04089
6	Bushing Driven	1	All	04088
7	Bearing Cutter Drum	2	All	04055
8	Belt	2	All	B42
9	Idle Rod Holder	1	All	04103
10	Idler arm all thread holder (Not Shown)	1	All	04172
11	Top Shaft Bearing	1	All	04084
12	Idle Bearing Cover	1	All	04024
13	Slot Retainer	2	All	04054
14	Skid Shoe	2	All	04056
15	Coupler	1	All	04071
16	Top Shaft Tube	1	MM60	04081
16	Top Shaft Tube (Not Shown)	1	MM48	04082
16	Top Shaft Tube (Not Shown)	1	MM72	04083
17	Top Shaft	1	MM60	04078
17	Top Shaft (Not Shown)	1	MM48	04079
17	Top Shaft (Not Shown)	1	MM72	04080
18	Rubber Skirt	1	MM60	04015
18	Rubber Skirt (Not Shown)	1	MM48	04016
18	Rubber Skirt (Not Shown)	1	MM72	04017

# Back Roller/Cutter Drum Assembly

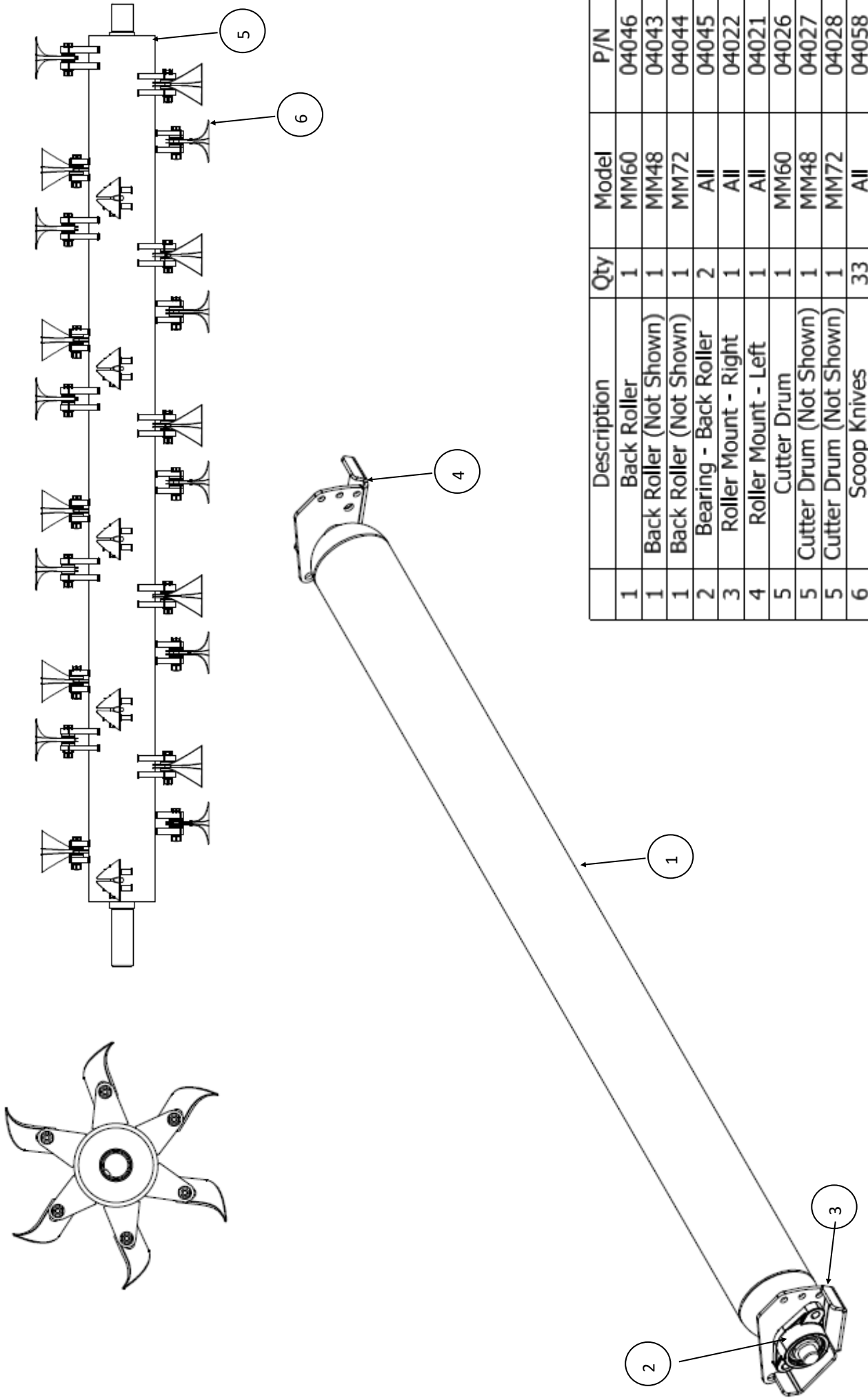

# PTO Shaft Assembly

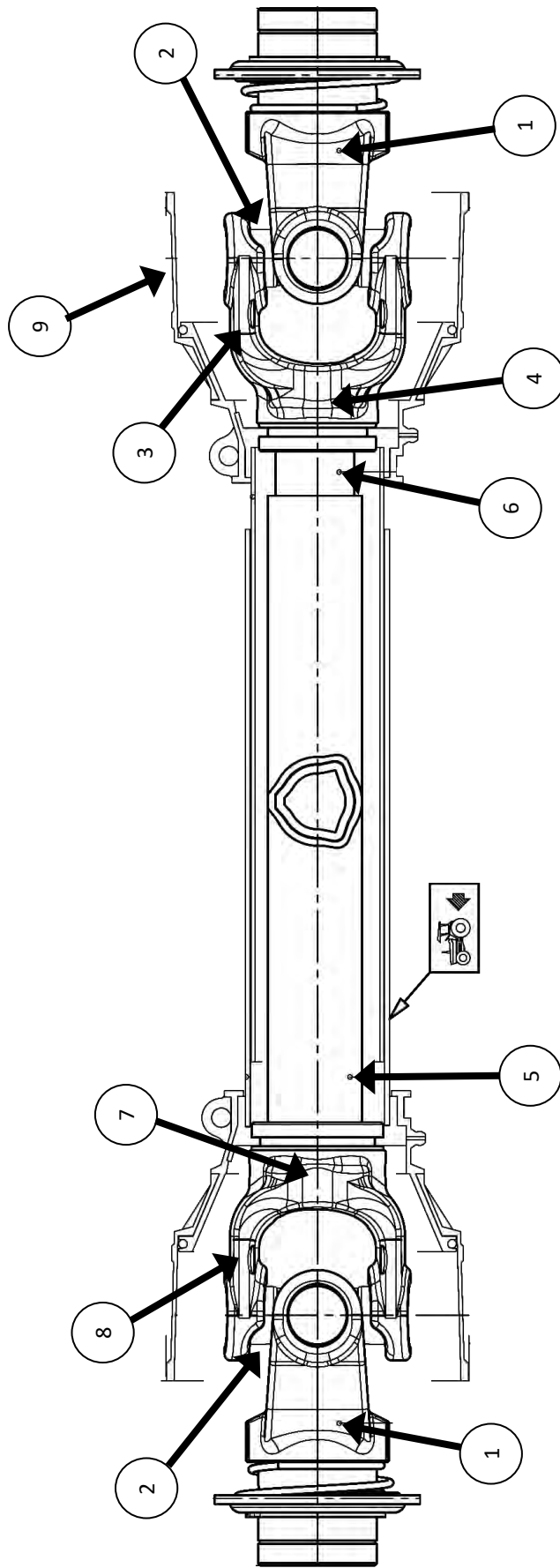

	Description	P/N
1	Yoke	DS-151
2	Cross Kits	DS-152
3	Yoke	DS-153
4	Roll Pin	DS-154
5	Cardan Tube	DS-155
6	Cardan Tube	DS-156
7	Roll Pin	DS-157
8	Yoke	DS-158
9	Complete Shield Kit	DS-159
10	Drive Line	DS-140

## Gearbox Assembly

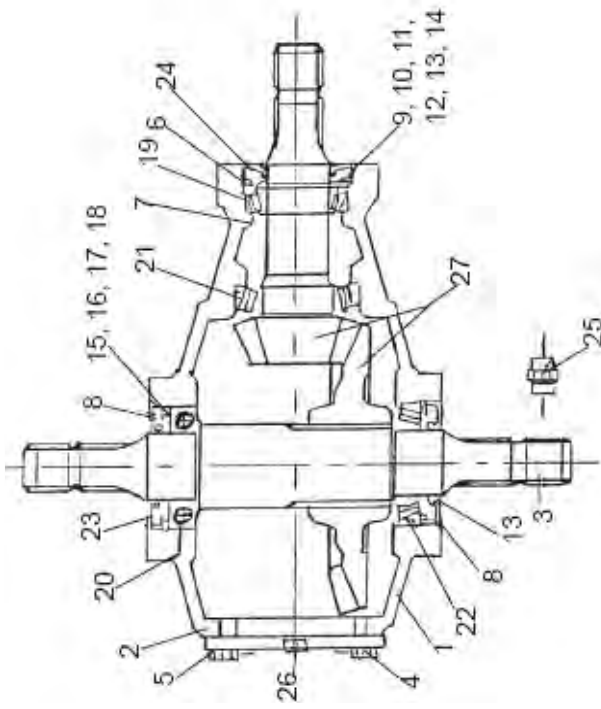

	Description	Model	P/N	Qty.
1	Main Housing	All	BP-2601	1
2	Rear Cover	All	BP-2602	1
3	Input Shaft	All	BP-2603	1
4	Cap Screw	All	BP-2605	4
5	Washer	All	BP-2606	4
6	Snap Ring	All	BP-2606	1
7	Snap Ring	All	BP-2607	2
8	Snap Ring	All	BP-2608	2
9	Shim Output Shaft 0.5 mm	All	BP-2609	A/R
10	Shim Output Shaft 0.8 mm	All	BP-2610	A/R
11	Shim Output Shaft 1.0 mm	All	BP-2611	A/R
12	Shim Output Shaft 0.3 mm	All	BP-2612	A/R
13	Shim Output Shaft 0.4 mm	All	BP-2613	A/R
14	Shim Output Shaft 0.2 mm	All	BP-2614	A/R
15	Shim Input Shaft 0.6 mm	All	BP-2615	A/R
16	Shim Input Shaft 0.8 mm	All	BP-2616	A/R
17	Shim Input Shaft 1.0 mm	All	BP-2617	A/R
18	Shim Input Shaft 0.3 mm	All	BP-2618	A/R
19	Ball Bearing	All	BP-2620	1
20	Ball Bearing	All	BP-2621	1
21	Tapered Bearing Assembly	All	BP-2622	1
22	Tapered Bearing Assembly	All	BP-2623	1
23	Oil Seal, Input Shaft	All	BP-2624	2
24	Oil Seal, Output Shaft	All	BP-2725	1
25	Breather	All	BP-2730	1
26	Oil Plug	All	BP-2726	4
27	Ring and Pinion Gear Set	All	BP-2627	1
28	Complete Gearbox Assembly	All	BP-2600	1

# Decals



P/N	Qty	Locations
DC-104	1	Idle Bearing Cover



P/N	Qty	Locations
DC-111	3	Shield
	1	Pulley Cage



## READ BEFORE OPERATING

- (a) Read the Owner's Manual before operating this machine.
- (b) Do not operate the machine without guards, shields, and other safety devices in place and in proper working condition.
- (c) Do not operate the machine when children and/or others are around.
- (d) Do not operate this machine unless you have received proper training.

**DC-109**

P/N	Qty	Locations
DC-109	1	Shield

## CAUTION

Moving components inside. Do not operate this machine without proper Guards in place.

P/N	Qty	Locations
DC-103	2	Pulley Cage



# Vrisimo

## FLAIL MOWERS & SHREDDERS

# Decals

P/N	Qty	Locations
DC-119	2	Shield

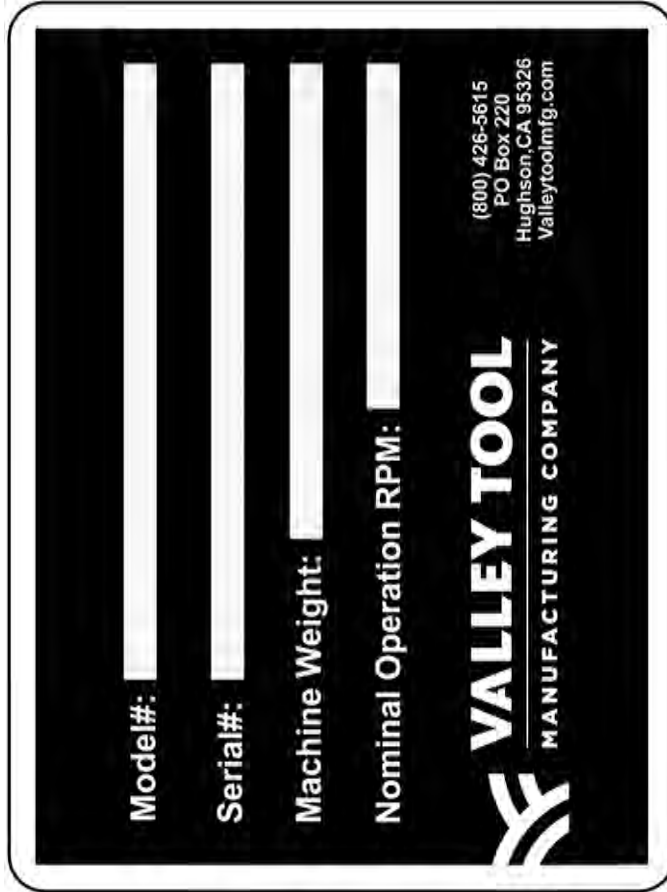

P/N	Qty	Locations
DC-118	1	Shield

# General

---

# Torque Specifications

Nominal Dia. (in)	Threads per inch	SAE J429 Grade 5		SAE J429 Grade 8		Holo-Krome Grade 9			
		Tightening Torque		Tightening Torque		Tightening Torque			
		Ecoguard	K=0.15	K=0.20	Ecoguard	K=0.15	K=0.20	Ecoguard	K=0.20
Unified Coarse Thread Series									
1/4	20	66 in-lbs	76 in-lbs	101 in-lbs	93 in-lbs	107 in-lbs	143 in-lbs	109 in-lbs	
5/16	18	136	157	209	192	221	295	225	
3/8	16	20 ft-lbs	23 ft-lbs	31 ft-lbs	28 ft-lbs	33 ft-lbs	44 ft-lbs	33 ft-lbs	
7/16	14	32	37	49	45	52	70	53	
1/2	13	49	57	75	69	80	106	81	
9/16	12	71	82	109	100	115	154	117	
5/8	11	98	113	150	138	159	212	161	
3/4	10	173	200	267	245	282	376	287	
7/8	9	279	322	429	394	455	606	462	
1	8	418	483	644	591	681	909	692	
1 1/4	7	728	840	1121	1181	1363	1817	1384	
1 3/8	6	955	1102	1469	1548	1786	2382	1815	
1 1/2	6	1267	1462	1950	2055	2371	3162	2409	
Fine Thread Series									
1/4	28	75 in-lbs	87 in-lbs	116 in-lbs	106 in-lbs	123 in-lbs	164 in-lbs	125 in-lbs	
5/16	24	150	174	231	212	245	327	249	
3/8	24	23 ft-lbs	26 ft-lbs	35 ft-lbs	32 ft-lbs	37 ft-lbs	49 ft-lbs	38 ft-lbs	
7/16	20	36	41	55	51	58	78	59	
1/2	20	55	64	85	78	90	120	91	
9/16	18	79	91	121	111	128	171	130	
5/8	18	110	127	170	156	180	240	183	
3/4	16	193	223	297	273	315	420	320	
7/8	14	308	355	474	435	502	669	509	
1	14	470	542	722	663	765	1020	777	
1 1/4	12	806	930	1241	1308	1509	2012	1533	
1 3/8	12	1087	1254	1672	1763	2034	2712	2066	
1 1/2	12	1426	1645	2194	2312	2668	3557	2710	

# Notes

---

# Notes

---



**MiniMax Series** *by*



**Vrisimo**

FLAIL MOWERS & SHREDDERS

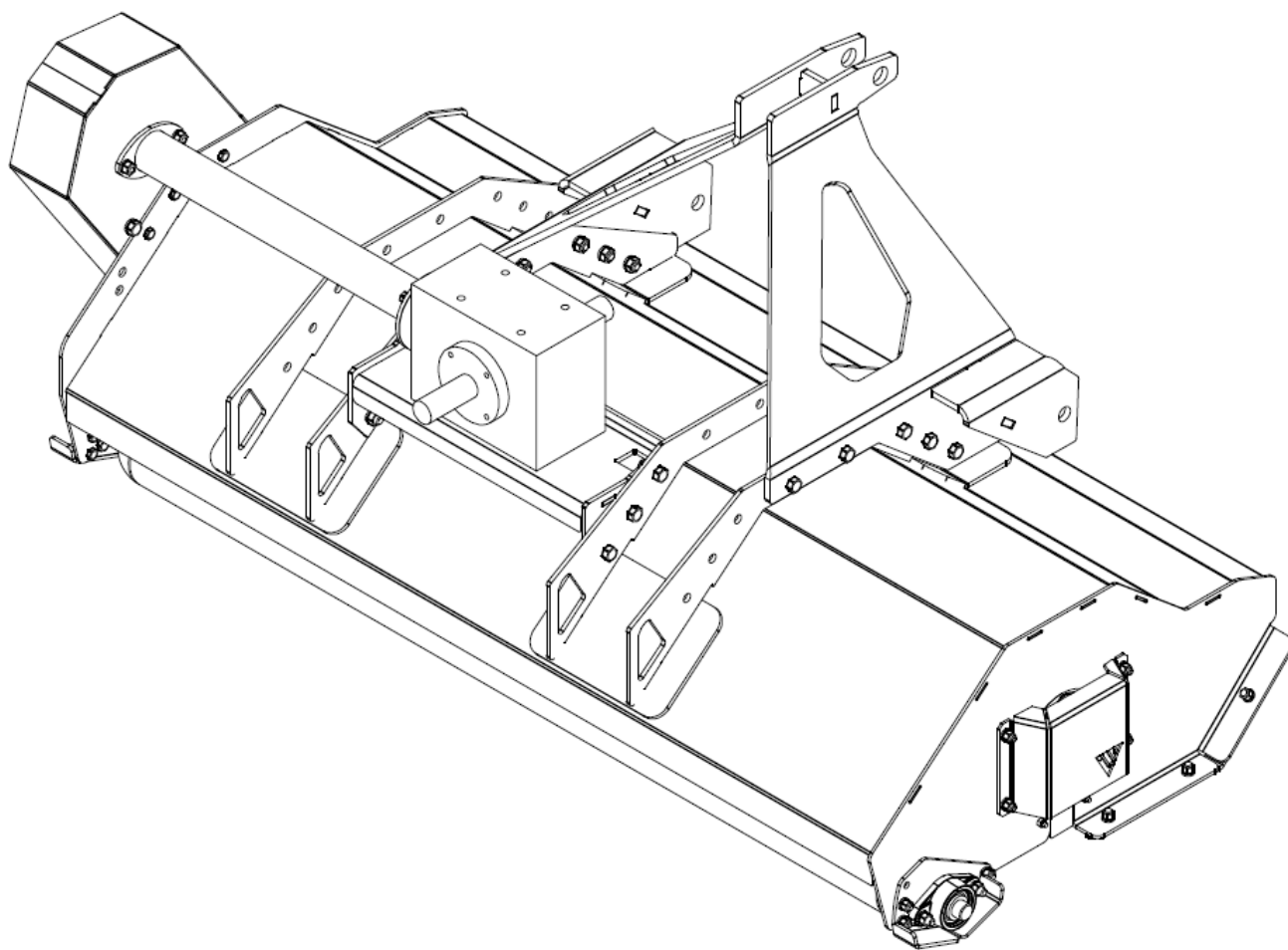

**MiniMax OWNER'S MANUAL**



**VALLEY TOOL**  
MANUFACTURING COMPANY

PO Box 220 | 2507 Tully Rd. | Hughson, CA 95326 USA |

800-426-5615

[www.Valleytoolmfg.com](http://www.Valleytoolmfg.com)