

**Super Series** *by*



**Vrisimo**

FLAIL MOWERS & SHREDDERS



**VALLEY TOOL**  
MANUFACTURING COMPANY

PO Box 220 | 2507 Tully Rd. | Hughson, CA 95326 USA |

800-426-5615

[www.Valleytoolmfg.com](http://www.Valleytoolmfg.com)

**Super Series OWNER'S MANUAL**



# Delivery Report Form

Prior to acceptance of the equipment, thoroughly check and mark off the items outlined in the delivery checklist below with your sales representative. Make sure you fully understand the operation, adjustment and safety rules as outlined in the operator's manual. The sales representative is responsible for going over this form with the owner and operator of this attachment. This form also serves as your warranty registration. Fax to 360-230-2322.

## Customer Information

Last Name		Street Address	
City	State	Zip	

## Attachment Information

Model	Serial Number
-------	---------------

## Dealer Information

Company Name		Sales Rep. Name	
Company Street Address	City	State	Zip

- Check to make sure attachment is completely lubricated.
- Buyer is shown all grease fittings and proper gear oil height.
- Oil in Gearbox checked for proper level and weight.
- All bolts checked for tightness.
- All hitch pins and retainer bolts in place.
- All knives and linkages in place.
- All shields in place.
- Belts checked for proper adjustment.
- PTO shaft checked for proper length.
- Procedures for attaching mower/shredder to tractor demonstrated to end user.
- Starting procedures explained to end user.
- Operation guidelines as outlined in owner's manual explained to end user.
- Adjustment of cutting height, belts and mower height explained to end user.
- Replacement of mower/shredder knives explained to owner.
- Lubrication points shown to end user.
- ALL safety precautions thoroughly read and understood.

**The signatures below indicate that both the sales representative and the end user have gone over the above checklist and all topics have been covered thoroughly.**

Buyer Signature \_\_\_\_\_ Date \_\_\_\_\_

Sales Rep. Signature \_\_\_\_\_ Date \_\_\_\_\_

**Fax this completed form to 360-230-2322.**



# Table of Contents

## Introduction

Thank You .....	1
Warranty Information .....	2

## Safety

Safety Procedures .....	3
Maintenance Safety.....	5

## Basic Operation

Attaching to Tractor .....	6
Starting Procedure .....	7
Running Your Mower .....	8

## Adjustments and Maintenance

Lubrication .....	9
Cutting Height and Belt Adjustment .....	10
Replacing the Knives .....	11
Cleaning Your Mower.....	12
Transport, Removal and Storage .....	13
Frequently Asked Questions.....	14

## Parts Catalog

Mower Information.....	16
Top Shaft Assembly.....	17
Pulley Assembly.....	18
Cutter Drum Assembly.....	19
PTO Shaft Assembly.....	20
Gauge Roller Assembly.....	21
Gearbox Assembly .....	22

# Thank You

Dear Customer,

Thank you for purchasing a Vrisimo Flail Mower or Shredder. This manual has been prepared to acquaint you with the operation, adjustment and maintenance of your new attachment. Your mower was carefully designed and manufactured under the highest industrial standards to give you years of dependable service. Read this Operator Manual carefully and fully understand the operation of the machine before attempting to operate it. Each section has been clearly identified so you can find the information you need. Vrisimo Equipment® reserves the right to make changes in design and specifications, and/or to make additions to or improvements in its product without imposing any obligation upon itself to install them on its products previously manufactured. If at anytime you require additional information, consult your authorized Vrisimo Equipment® dealer or the customer service department.

## ATTENTION

The safety of the operator was one of the primary concerns of Vrisimo Equipment® when designing this attachment. Shielding, simple adjustments and other safety features were built into this mower whenever possible. You can make your home, orchard or farm a safer place to live and work if you observe the precautions following this message. Be sure you and the people working for you read and understand them. All machinery should be operated only by responsible persons who have been trained to operate them in a safe manner.



**Vrisimo Equipment®** is solely owned by Valley Tool and Manufacturing.

Have industrial applications? Own a skid steer or mini excavator? Visit [www.rockhound.com](http://www.rockhound.com) for our full line of industrial applications.

Vrisimo Equipment  
P.O. Box 220 - 2507 Tully Rd.  
Hughson, CA 95326  
Phone (800) 426-5615 Fax (360) 230-2322

# Important to Purchaser

## Customer Ownership Registration

Prior to acceptance of the equipment, thoroughly check off the pre-delivery checklist with the sales representative. Be sure you fully understand the operation, adjustment and safety rules as outlined in this manual.

### Delivery Checklist

- Check to make sure mower/shredder is lubricated.
- Buyer is shown all grease fittings and proper gear oil height.
- Oil in gearbox checked for proper level and weight.
- All bolts checked for tightness
- All hitch pins and retainer bolts in place.
- All knives and linkages in place.
- All shields in place.
- Belts checked for proper adjustment.
- PTO shaft checked for proper length.
- Procedures for attaching mower/shredder to tractor demonstrated to end user.
- Starting procedures explained to end user.
- Operation guidelines as outlined in owner's manual explained to end user.
- Adjustment of cutting height, belts and mower height explained to end user.
- Replacement of mower/shredder knives explained to owner.
- Lubrication points shown to end user.
- ALL safety precautions thoroughly read and understood.

### Warranty

Vrisimo Equipment guarantees the Vrisimo Flail Mower to be free from defect in material and workmanship for a period of six months dating from delivery to the original user. The obligation under this warranty, statutory or otherwise, is limited to the replacement and/or repair at your authorized Vrisimo dealer of such part or parts as shall appear to us, upon inspection, to have been defective in material or workmanship and not altered in any way by the customer or other parties.

This warranty shall not apply to vendor warranted PTO items such as bearings, belts, PTO shafts and gearboxes or other parts not manufactured by Vrisimo Equipment. Such being subject to the warranty of their respective manufacturers.

No expressed, implied or statutory warranty other than herein set forth is made or authorized to be made by us. Vrisimo Equipment shall not be liable for consequential damages of any kind, including but not limited to: consequential labor costs or transportation charges in connection with the replacement or repair of defective parts, lost time or expense which may have accrued because of said defects.

Vrisimo reserves the right to make changes in its products at any time and without prior notice. When such changes are made, neither Vrisimo Equipment nor its dealers assume any obligation to make these changes in products previously manufactured.

# Safety

**Failure to heed these warnings may result in personal injury or death.**

- Before operating this machinery, read the owner's manual carefully.

- Use eye, ear and head protection to protect the operator from any flying debris and noise



- Use a backboard made of plywood or similar material behind the tractor seat for added driver protection. Because of the wide variety of tractors used with the Vrisimo mowers/shredders, it is the purchaser's responsibility to insure that a backboard is constructed and installed on each tractor being used to run the mower/shredder. The use of this shredder without a backboard installed on the tractor can result in serious personal injury or death from debris that might be discharged or thrown from the mower/shredder unit.

- All personnel except tractor driver should be 100 feet clear of machinery before starting or operating it.

- Never use drugs or alcohol before or while operating your mower/shredder.



- Be aware that driving a tractor for an extended period of time can result in fatigue or boredom and may cause the operator to lose awareness of what he/she is doing. It is recommended that scheduled work breaks be taken to avoid this.

- Keep hands and loose clothing away from any power driven parts.

- Avoid contact with hot surfaces including pumps, motors, hydraulic oil tanks and hose connections.

- Do not operate this machine without all guards being in good condition and firmly in place.

- Do not operate this machine on a tractor that is not properly maintained. If a tractor control failure should occur while operating this machine, immediately shut down the tractor and perform repairs before continuing.



## Safety (cont.)

- Stop the operation of this machine when people or vehicle driver's vision becomes obscured, caused by the discharge of materials and dust. Also avoid operating this machinery in unusually foggy conditions or at night.
- Never leave the mower/shredder unattended while it is in the lifted position.
- Keep away from rotating elements to prevent entanglement.



- Do not let the mower blades turn while the mower deck is raised for any reason.
- Use flashing warning lights when operating on highways, except when prohibited by law.
- Be aware that the mower/shredder may be wider than the tractor, and caution should be used to avoid clipping or running over trees, signs or posts that may be in the way of the mower/shredder.
- Never allow children or other persons to ride on the mower.



- Mow at a speed you can safely operate the tractor and mower. Normal ground speed ranges from 0-5 miles per hour. Use slow mowing speeds when operating on or near slopes, ditches, drop-offs, or when debris and foreign objects are to be avoided.
- Use the following guidelines to reduce the risk of equipment and grass fires:
  - Do not smoke or have an open flame near the tractor or mower.
  - Do not drive into burning areas or areas that have been freshly burned.
  - Insure slip clutches are properly adjusted to prevent excessive slipping.
  - DO NOT allow clippings or debris to collect near drivelines, slip clutches and gear-boxes. Check the mower deck periodically and clear out any clippings and collected debris.
- Do not turn so sharp or lift the mower so high that the driveline produces a severe knocking. This will cause accelerated wear and eventually the destruction of drive train components.

# Maintenance Safety

- Be sure to inspect all safety devices (including safety shields, guards, deflectors, etc.) before each use.

**Safety Shield Examples**



- Maintain all safety decals and make sure they are visible to the operator.
- Replace bent or broken blades with new ones. **DO NOT** attempt to weld or bend damaged blades. This can cause cracking or other types of damage that could result in the blade being thrown from the mower.
- Wear gloves and exercise care when handling mower blades/knives. Also be alert to worn or damaged surfaces that could have sharp edges.
- Disengage PTO and shut off engine allowing all movement to stop before leaving the operator's position to adjust, clean, lubricate or unplug the machine.
- Replace rubber guard on the front of the mower/shredder if torn, frayed, punctured, or worn before operating this equipment.
- Before working on or underneath the mower/shredder, place blocks on both sides (front and back) of tractor tires and under each end of the mower to prevent accidental lowering of the machine. Also remove the ignition key from the tractor and allow all movement to stop before beginning work.

# Basic Operation

## Attaching to Tractor

The Vrisimo flail can be hooked up to any 3-point hitch within its category and 540 PTO tractors. The tractor's drawbar should be placed to its shortest point. If there is still insufficient clearance, then it should be removed. On tractors with load and depth control, lock out control so it will not function but still be in "free float."



1. Back the tractor so the lift links are in-line with the mower's hitch pins.
2. Shut off engine and disengage PTO. Block tractor wheels before you place yourself between the tractor and the mower.
3. Attach the tractor's left and right lift links to the corresponding hitch pins of the mower. Secure both connections with lynch pins.
4. Adjust sway chains or bars so there is a minimum of side slack. Be sure the stabilizers are tight.
5. Attach the tractor's top link to the "A" frame of the mower. Adjust the link out to the approximate desired cutting height.
6. Attach the PTO to the tractor by pushing in on the quick disconnect pin. Remember, tube end goes to the mower and bar end goes to the tractor.
7. Do not raise the mower while the PTO is engaged, since this will cause the shaft to bind or even break, and may cause injury to the operator.

### **ATTENTION**

**Before operating the mower under power, be sure to check the drive shaft through the entire lifting range to assure that there is no binding, bottoming, or uncoupling of the shaft connection.**

# Basic Operation

## Starting Procedure

### ATTENTION

**Do not start the tractor until mower has been carefully checked for correct assembly and installation. Be sure all observers are at least 100 feet clear of the machine.**

1. Check to see that the mower is in the down position and blades are not touching the ground. Start the engine. Set throttle at idle speed and slowly engage the PTO.

### WARNING

**Do not engage the PTO at a high engine speed. You may damage the mower and possibly the tractor's PTO system.**

**Do not operate with tractors having 1000 RPM PTO speeds unless the mower has been specifically designed to run at that speed. This high speed will damage the mower and possibly cause injury.**

2. Increase engine RPM to 540 PTO speed for a few minutes. Check for any excess vibration or loose parts.

**IMPORTANT: If excess vibrations occur, disengage the tractor PTO shaft IMMEDIATELY. Shut off the tractor and determine and correct the cause of the problem. The rotor shaft has been electronically balanced to within 2 mils, which must be maintained throughout the life of the machine.**

3. Shut off tractor engine, shut off PTO, put tractor in park, set parking brake and check PTO shaft, all bearings and gearbox for excess heat or oil leaks.

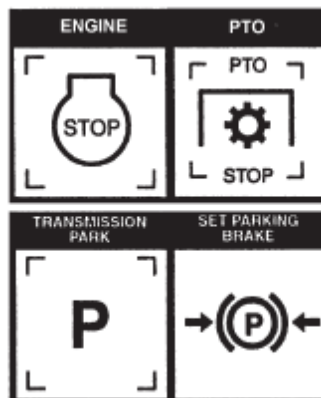

# Basic Operation

## Running Your Mower

### ATTENTION

The mower should be run at a 540 RPM PTO speed unless it has been specifically designed to run at a higher PTO speed.

1. Ground speed should range anywhere from 0-5 miles per hour. However, the operator should drive at a speed he or she is comfortable with within this range.
2. The skid shoes should be 1/2" to 3" off of the ground. Skid shoes are not made to run on the ground.
3. The skid shoes and mower should be level with the ground while running the mower.
4. The weight of the mower should be on the back gauge roller, which runs on the ground.
5. Check adjustments section if you need to adjust the height of your mower.



Back Roller on the Ground

Skid Shoes off the Ground

# Adjustments and Maintenance

## ATTENTION

Before doing any service work, observe the following safety rules:

1. Allow all movements to stop before leaving the operator's position to lubricate or clean the machine.
2. Before working on or underneath the mower, place blocks on both sides of the rear tractor tires and under each end of the mower to prevent accidental lowering of the machine.
3. Remove the ignition key from the tractor and allow all movements to stop before beginning work.

## Lubrication

1. Grease Daily: Five bearings, three universal joints and drive shaft slide tube.

## CAUTION

Over-greasing seals and bearings can cause damage. If an excessive amount of grease comes out, too much grease has been applied.

2. Check gearbox oil level periodically and refill as required with quality 90 wt. gear oil. Be sure gearbox is in level position and remove side plug to fill.

## CAUTION

Do not overfill gearbox. Seal ruptures can occur.

**Lube Points:**  
(may vary)

U-Joint Bearings

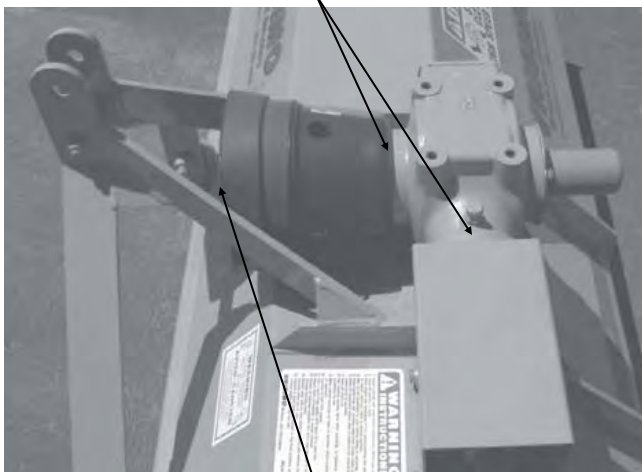

PTO Extension Shaft Bearings

1 Top Shaft Bearing (Behind Pulley)

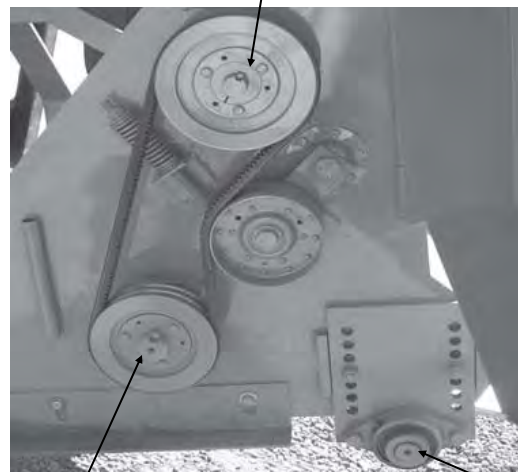

2 Main Cutter Drum Bearings (One on each side behind pulley)

2 Back Gauge Roll Bearings (One on each side)

# Adjustments and Maintenance

## Cutting Height, Skid Shoes, and Belt Adjustment

1. The cutting height of the mower can be adjusted from 0-8". Adjustment is done by shortening or lengthening the top-link. **UNDER NO CIRCUMSTANCES SHOULD THE KNIVES CONTACT THE GROUND!**

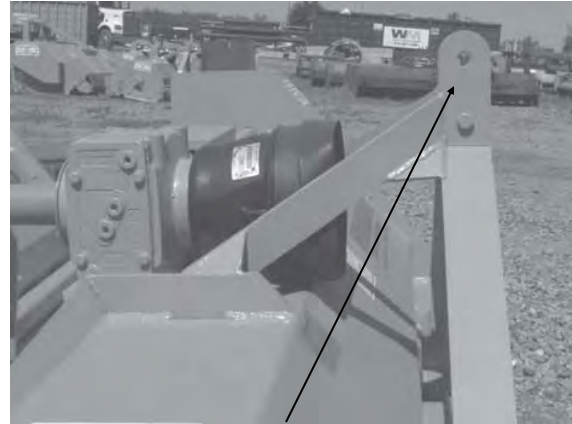

**Adjustable Top-Link**

2. The entire weight of the mower should be on the back gauge roller. The skid shoes should be adjusted so there is 1/2"-3" clearance between them and the ground. The shoes are for added protection against tree roots, ridges or borders and are not designed to slide on the ground. Adjust the back gauge roller by removing the bolts from both sides and resetting it to the correct

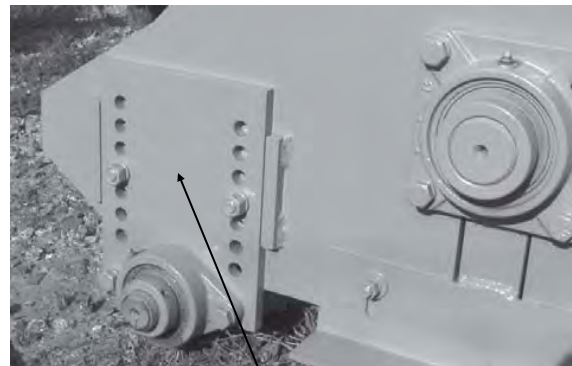

**Back Gauge Roller Adjustment**

3. Belt adjustment is done by tightening the idler adjusting rod which pulls the idler pulley into the belts. On a new machine, after 1-2 hours of operation, tighten the drive belts so there is only 1/4" to 3/8" give with 8 pounds of force.

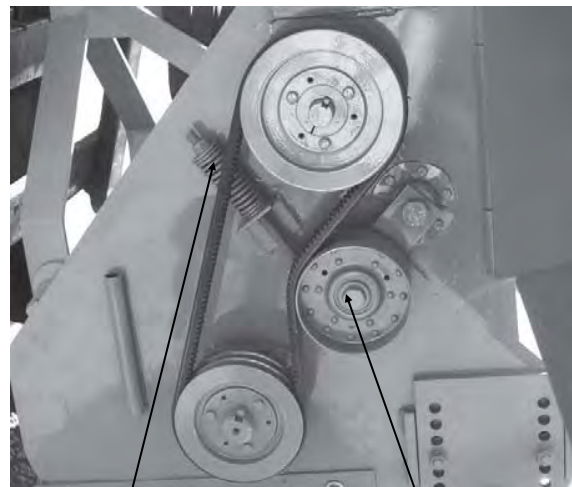

**Idler Adjusting Rod**

**Idler Pulley**

# Adjustments and Maintenance

## Replacing the Knives and Skid Shoes

1. When knives, bolts or spacers become worn, they must be replaced. Not doing so could cause the cutter drum to run out of balance.

### **ATTENTION**

**An unbalanced cutter drum can result if new knives or parts are mixed with worn parts. Wear gloves at all times when handling knives.**

2. Replacing the knives is done by disconnecting the mower and tipping it up on its front end. Remove both skid shoes by removing the bolts holding them in place. Look in the gap created by the skid shoe on the side where the pulley system is located and remove the cotter pin that is inserted into the end of the hanger rod. Go to the other side and pull the rod out. The knives should drop out.
3. Once the knives have dropped out, replace with new ones by pushing the rod in while someone holds the new knives in place.
4. Install cotter pin and re-install skid shoes.

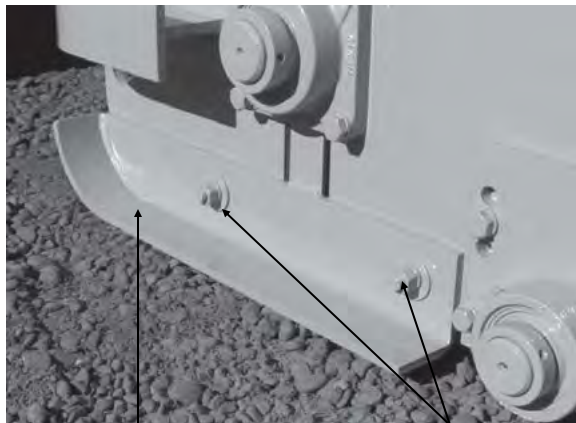

Skid Shoe

Remove

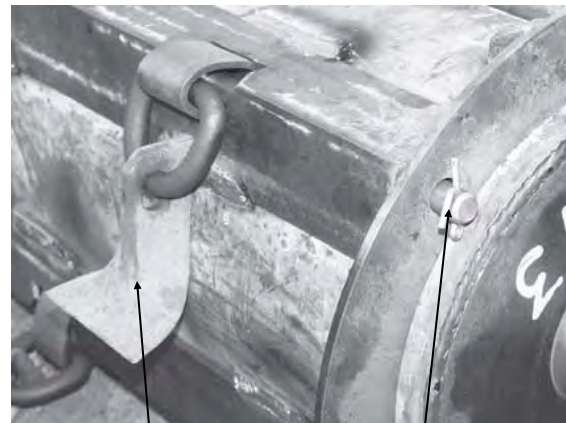

Scoop Knife

Hanger Rod w/ Pin



Skid Shoe Area

Hanger Rod



# Adjustments and Maintenance

## Cleaning Your Mower

### ATTENTION

To preserve life of paint and decals, wash the mower after each use. The preservation of your mower's decals is essential to safety, so make sure they are kept in good condition.

It is recommended that some sort of degreasing solution be used on all bearings.

1. Check for excessive grease in bearing areas on the pulley side of the mower. Make sure that grease is not allowed to get into the belt areas.

Check bearing areas underneath pulleys and remove any caught clippings.

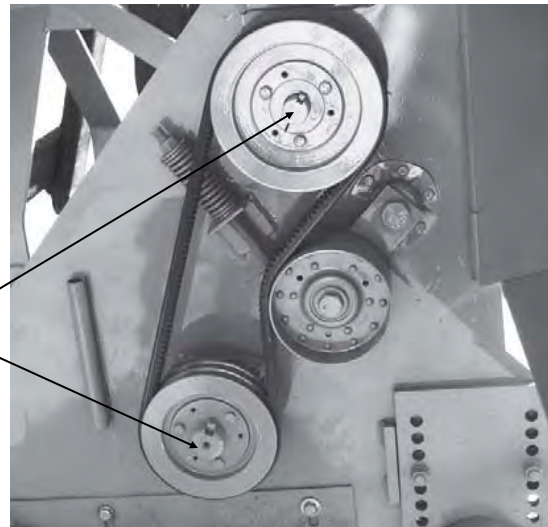

2. Clean any clippings from gearbox areas, pulley areas and anywhere else that is prone to excessive heat where fires can start.

Check gearbox area and under safety shields for clippings.

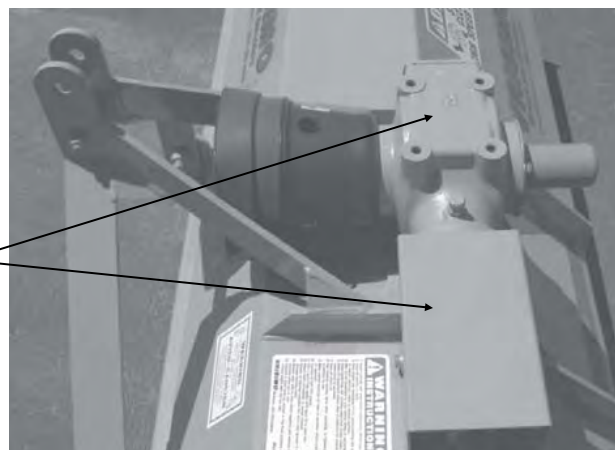

3. Clean the inside of the mower with a pressure washer. Make sure the inside of the mower is kept free from mud and compact grass. Keep in mind that mud built up on the cutter drum can cause imbalance.
4. Preserve damaged decals or replace them if they are unreadable. Decal kits can be obtained from your local Vrisimo dealer.

# Transport, Removal and Storage

## ATTENTION

**To transport, disengage PTO lever before lifting mower to the highest transport position. Raising the mower while the PTO is engaged will cause the shaft to bind or even break and may cause injury to the operator.**

Disengage PTO and shut off engine allowing all movement to stop before leaving the operator's position to adjust, lubricate, clean or unclog the machine. Before working on or underneath the mower/shredder, place blocks on both sides (front and rear) of tractor tires and under each end of the mower to prevent accidental lowering of the machine. Also remove the ignition key from the tractor and allow all movement to stop before beginning work.

## Removal

1. Remove the adjustable top link from the tractor and mower.
2. Disconnect the drive shaft from the tractor and mower.
3. Remove the safety pins from the lower three point arm pins and pull the arms off the pins.

## Storage

1. Put the drive shaft away in a clean, dry place.
2. Clean the mower thoroughly.
3. Relax belt tension.
4. Lubricate the mower as recommended.
5. Check oil level in gearbox and fill as required.
6. Check for worn parts and replace so you will be ready to mow when necessary.
7. Store in a clean, dry place.

## Frequently Asked Questions

- Q. Where is the serial number for my machine?  
R. Look at the base of the gearbox, it is stamped on the gearbox mount.

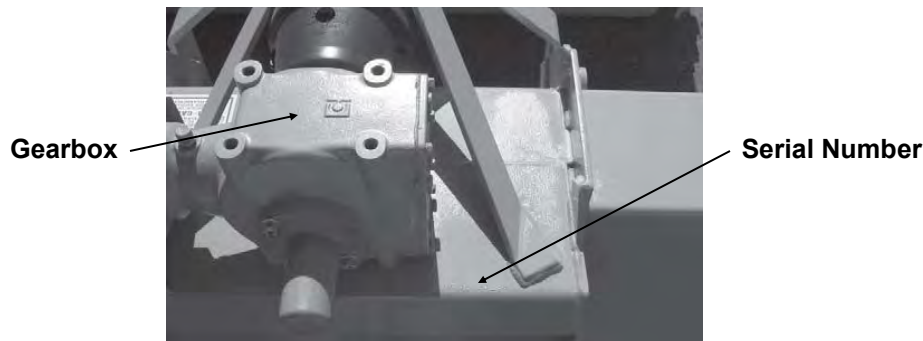

- Q. Where do I find replacement parts?  
R. First check your local tractor dealer and if they do not have parts, ask them to order from the Vrisimo factory.
- Q. How often should I change my knives?  
R. Replacing the cutting knives is entirely up to the owner. When the cut begins to be inconsistent or rough, consider replacing the knives. It is recommended to keep an extra set of knives on hand so that loss of work time is minimal.
- Q. How often should I replace my belts?  
R. If you are experiencing repeated slipping or breaking of belts, try adjusting the level of tension. If this does not remedy the problem, replace the belt. Consider having an extra belt on hand as well.
- Q. Do I need to fill the gearbox with oil before I use the mower?  
R. No, the gearbox comes full with oil. Use 90 weight oil when replacing.
- Q. What do I do if my belts are wearing out too fast or burning up?  
R. First check belt tension. Belts should have about 3/8" sway in them. Adjust tension accordingly. If this does not help, check the height of the grass you are mowing. If the grass is over 2 feet tall, you might have to adjust mower cutting height upwards and slow the speed of your travel to reduce belt slippage.
- Q. My side skid shoes are wearing out too quickly. What do I do?  
R. Operate the mower with the side skid shoes 0.5-3 inches off the ground. The side skid shoes are meant to collide only with mounds or objects in the field. The rear roller is the only part of the mower that should touch the ground during operation.
- Q. How can I prevent my PTO shaft from coming off during operation?  
R. Be careful! Make sure the shaft is slid all the way on and the safety pin is in the locked position.

## Frequently Asked Questions

- Q. When I am replacing gear oil, how much should I add?  
R. When replacing gear oil, fill from the lower-middle fitting and when oil begins to come out, the box is full.

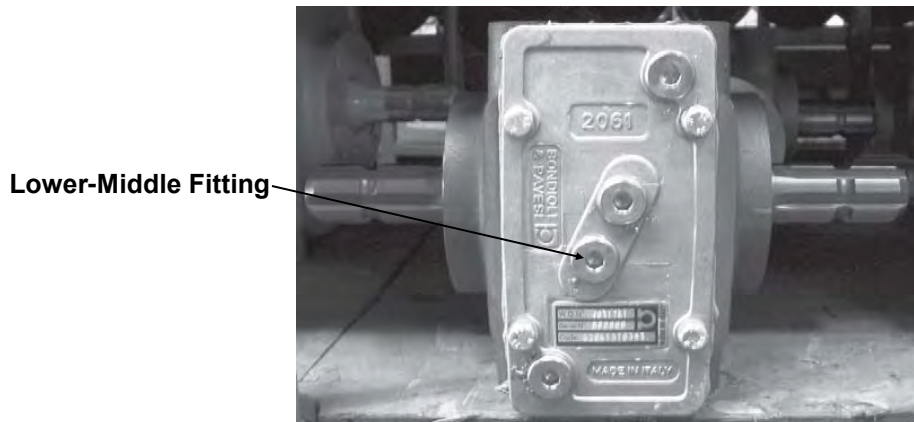

- Q. Are there any advantages to reversing cutter drum rotation?  
R. Whether or not reversing cutter drum is advantageous depends on the application. In most mowers (excluding the Roadside), normal rotation is a reverse rotation. This means that the cutter drum rotates in a fashion that would throw grass or clippings towards the tractor. The only advantage to reversing rotation would be if you are mowing in industrial applications such as along freeways, in places with large amounts of debris (i.e. plastic, metal, rocks), or using a front mount application or a Roadside. There are typically no advantages as far as the grade of cut you will get, but rather safety advantages as stated above.
- Q. How do I reverse cutter drum rotation?  
R. To reverse cutter drum rotation, simply un-mount the gearbox from its current position, remove the safety cover from the other shaft of the gearbox and rotate the gearbox so that the previously covered shaft is the one that will be driven by the PTO. Install the safety covers and it is ready to go. Note: Scoop knives must be rotated to accommodate for a reversed cutter drum rotation.
- Q. How do I replace my knives?  
R. Replacing the knives may vary depending on your model of mower/shredder. See the Adjustments/Maintenance section for detailed information.
- Q. When connecting my PTO shaft, can I put it on either way or should a specific side go to the mower/shredder and the other to the tractor?  
R. The PTO shafts for these mowers/shredders are side specific. The tube half of the PTO shaft goes to the mower/shredder and the bar half of the PTO shaft goes to the tractor.

## Parts Catalog



### Super Series

#### Super Series Specifications

Model	Cutting Height	Cutting Width	Overall Width	Appx. HP	Scoop Knives	Ind. Knives
SC148	0-6"	48"	58"	20-22	21	42
SC160	0-6"	60"	70"	20-22	27	54
SC174	0-6"	74"	84"	30-50	36	72
SC188	0-6"	88"	98"	30-50	39	78
SC1100	0-6"	100"	110"	40-60	45	90
SC1120	0-6"	120"	130"	40-60	54	108

Model	Main Shaft Dia.	Gauge Roller Dia.	Top Shaft Dia.	Drive Belt	Appx. Shipping Weight
SC148	1 15/16"	5 5/8" OD	1 3/8"	3/Banded	705 lbs.
SC160	1 15/16"	5 5/8" OD	1 3/8"	3/Banded	835 lbs.
SC174	1 15/16"	5 5/8" OD	1 3/8"	3/Banded	980 lbs.
SC188	1 15/16"	5 5/8" OD	1 3/8"	3/Banded	1095 lbs.
SC1100	1 15/16"	5 5/8" OD	1 3/8"	3/Banded	1230 lbs.
SC1120	1 15/16"	5 5/8" OD	1 3/8"	3/Banded	1445 lbs.

### Top Shaft Assembly

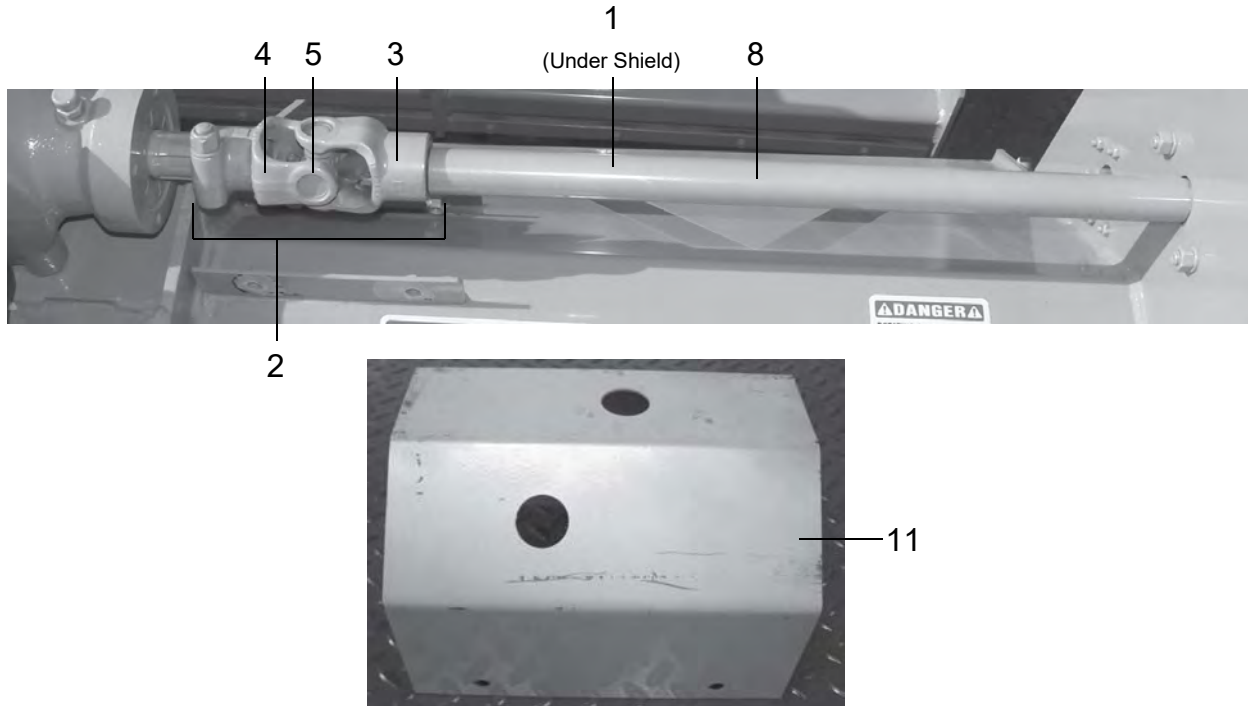

#	Description	Model	Part #	Qty.	Year
1	Top Shaft 1 3/8" 14" Center Mount	SC148	TS-105-14	1	1994+
1	Top Shaft 1 3/8" x 8" 6" Offset	SC148	TS-105-08	1	1994+
1	Top Shaft 1 3/8" x 20" Center Mount	SC160	TS-105-20	1	1994+
1	Top Shaft 1 3/8" x 14" 6" Offset	SC160	TS-105-14	1	1994+
1	Top Shaft 1 3/8" x 11" 9" Offset	SC160	TS-105-11	1	1994+
1	Top Shaft 1 3/8" x 27" Center Mount	SC174	TS-105-27	1	1994+
1	Top Shaft 1 3/8" x 21" 6" Offset	SC174	TS-105-21	1	1994+
1	Top Shaft 1 3/8" x 18" 9" Offset	SC174	TS-105-18	1	1994+
1	Top Shaft 1 3/8" x 34" Center Mount	SC188	TS-105-34	1	1994+
1	Top Shaft 1 3/8" x 28" 6" Offset	SC188	TS-105-28	1	1994+
1	Top Shaft 1 3/8" x 25" 9" Offset	SC188	TS-105-25	1	1994+
1	Top Shaft 1 3/8" x 40" Center Mount	SC1100	TS-105-40	1	1994+
1	Top Shaft 1 3/8" x 34" 6" Offset	SC1100	TS-105-34	1	1994+
1	Top Shaft 1 3/8" x 31" 9" Offset	SC1100	TS-105-31	1	1994+
1	Top Shaft 1 3/8" x 50" Center Mount	SC1120	TS-105-50	1	1994+
1	Top Shaft 1 3/8" x 38" 12" Offset	SC1120	TS-105-38	1	1994+
2	Complete Universal Assembly	All	TS-1085	1	1994+
3	Yoke 1 3/8" Round Bore, Keyed	All	DS-2225	1	1994+
4	Yoke 1 3/8" Six Spline	All	DS-2223	1	1994+
5	Universal Cross Assembly	All	DS-2230	1	1994+
6	Bearing Assembly 1 3/8" 2 Bolt (Not shown)	All	TS-1306	1	1994+
7	Bearing Assembly 1 3/8" PB CM (Not shown)	SC1120	TS-1300	1	1994+
8	Top Shaft Safety Shield (Per ft.)	All	TS-1199	A/R	1994+
9	Roll Pin, Universal Top Shaft (Not shown)	All	TS-1198	1	1994+
10	Key 3/8" x 2" (Not Shown)	All	TS-1194	1	1994+
11	Guard and Cover for Universal	All	TS-119	1	1994+

## Pulley System

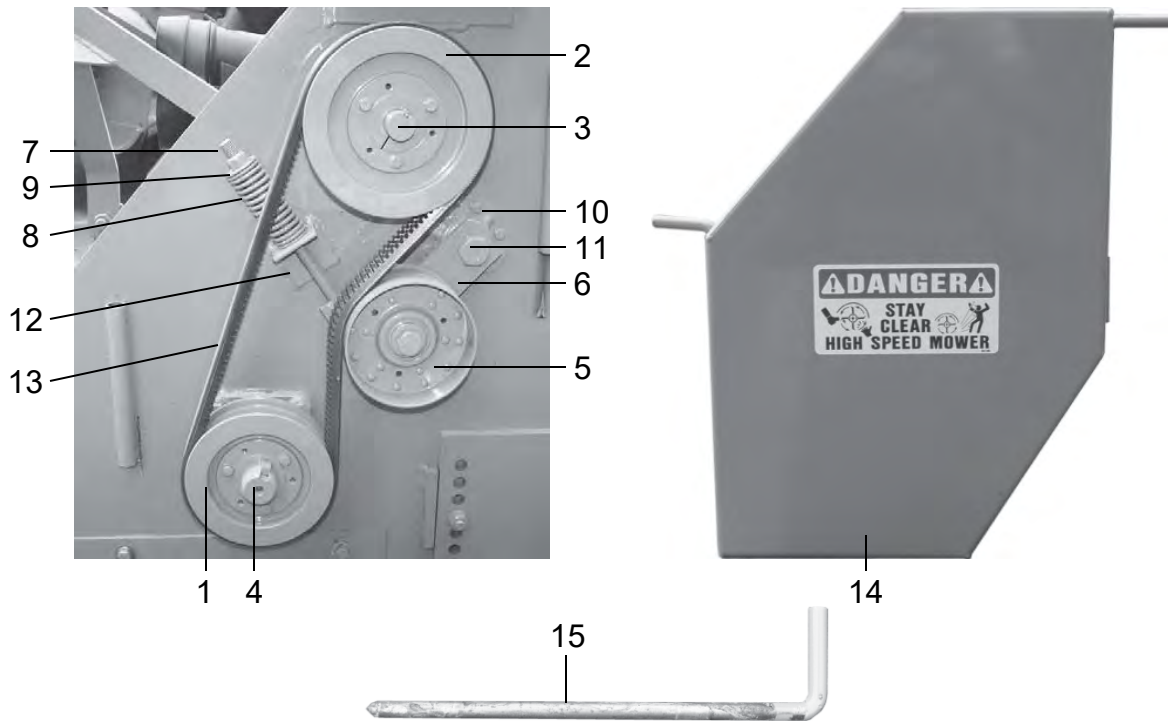

#	Description	Model	Part #	Qty.	Year
1	Lower Pulley, 3 Groove 6.2" OD	SC148-SC1100	P-131	1	1994+
1	Lower Pulley, 3 Groove 6.6" OD	SC1120	P-133	1	1994+
2	Upper Pulley, 3 Groove 7.4" OD	SC148-SC1100	P-132	1	1994+
2	Upper Pulley, 3 Groove 7.0" OD	SC1120	P-134	1	1994+
3	Retainer Bushing 1 3/8" ID	SC148-SC1100	TL-1540	1	1994+
3	Retainer Bushing 1 3/8" ID	SC1120	TL-138	1	1994+
4	Retainer Bushing 1 15/16" ID	All	TL-1630	1	1994+
5	Idler Pulley	All	IP-145A	1	1994+
6	Idler Arm	All	IP-146A	1	1994+
7	Idler Arm Adjusting Rod	All	IP-147A	1	1994+
8	Idler Arm Spring	All	IP-149	1	1994+
9	Idler Spring washer	All	IP-150	1	1994+
10	Idler Arm Bearing	All	IP-151	1	1994+
11	Idler Bearing Washer	All	IP-152	1	1994+
12	Idler Spring Seat	All	IP-154	1	1994+
13	Banded Drive Belt, 3 Groove	All	B-156A	1	1994+
14	Drive Belt Cover	All	B-158	1	1994+
15	Drive Belt Cover Retaining Pin	All	DP-1003	2	1994+

## Cutter Drum Assembly

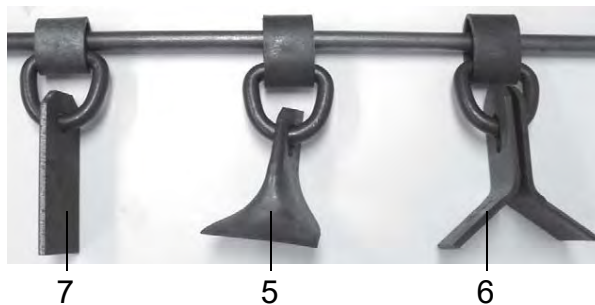
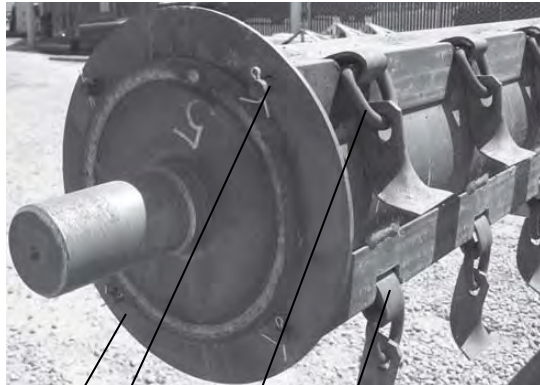

#	Description	Model	Part #	Qty.	Year
1	Bare Cutter Drum 1 15/16" Shafts	SC148	CD-162	1	1994+
1	Bare Cutter Drum 1 15/16" Shafts	SC160	CD-163	1	1994+
1	Bare Cutter Drum 1 15/16" Shafts	SC174	CD-168A	1	1994+
1	Bare Cutter Drum 1 15/16" Shafts	SC188	CD-169A	1	1994+
1	Bare Cutter Drum 1 15/16" Shafts	SC1100	CD-170A	1	1994+
1	Bare Cutter Drum 1 15/16" Shafts	SC1120	CD-179	1	1994+
2	Hanger Rod	SC148	CD-178	3	1994+
2	Hanger Rod	SC160	CD-1900	3	1994+
2	Hanger Rod	SC174	CD-174	3	1994+
2	Hanger Rod	SC188	CD-175	3	1994+
2	Hanger Rod	SC1100	CD-176	3	1994+
2	Hanger Rod	SC1120	CD-1950	4	1994+
3	Oval Hanger	All	CD-2120	A/R	1994+
4	D Ring	All	CD-2135	A/R	1994+
5	Scoop Knife	All	CD-2110	A/R	1994+
6	Industrial Knife	All	CD-2100	A/R	1994+
7	Thatching Knife	All	CD-2115	A/R	1994+
8	Bearing Assembly 1 15/16" 4 Bolt	All	CD-1800	2	1994+



## PTO Shaft Assembly

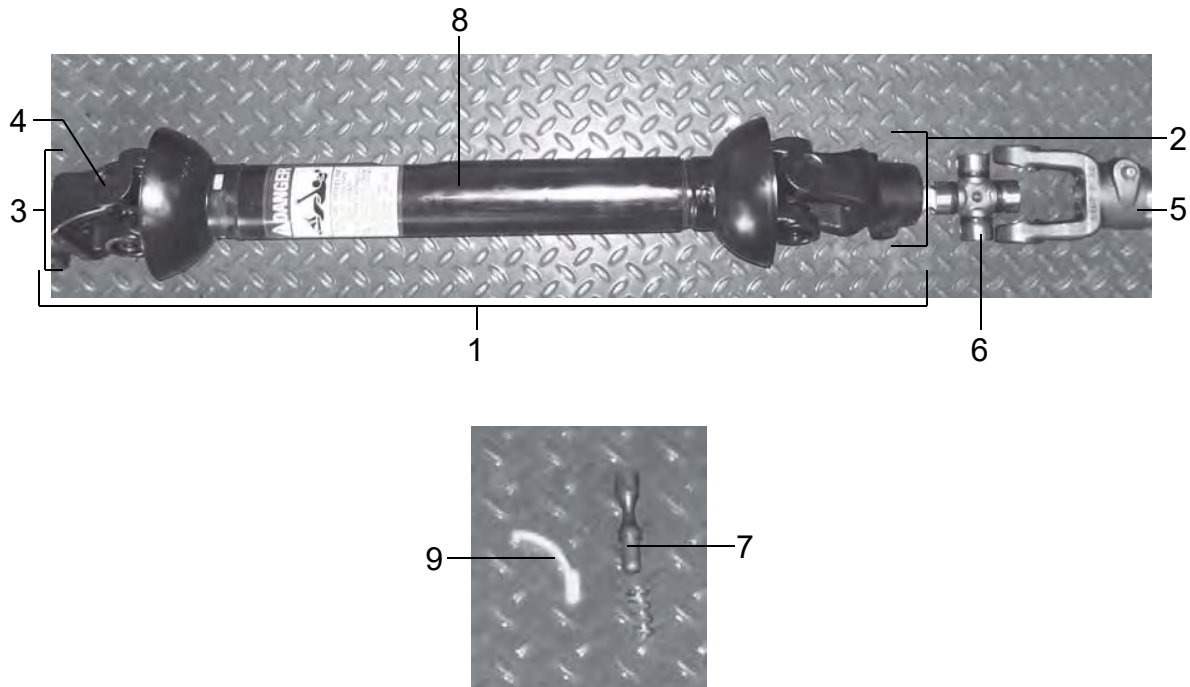

#	Description	Model	Part #	Qty.	Year
1	Complete PTO Shaft Assembly	All	DS-2200	1	1994+
2	Complete Tube End	All	DS-2212	1	1994+
3	Complete Bar End	All	DS-2214	1	1994+
4	Yoke, Tractor End 1 3/8" QD	All	DS-2220	1	1994+
5	Yoke, Mower End 1 3/8" QD	All	DS-2220A	1	1994+
6	Cross Repair Kit	All	DS-2230	2	1994+
7	QD Pin Set	All	DS-2640	2	1994+
8	Shield Set	All	DS-193A	1	1994+
9	Shield Retaining Kit	All	DS-194	2	1994+

### Gauge Roller Assembly/Miscellaneous

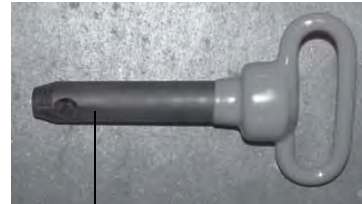

#	Description	Model	Part #	Qty.	Year
1	Rear Gauge Roller 1 7/16" Shafts	SC148	BR-222	1	1994+
1	Rear Gauge Roller 1 7/16" Shafts	SC160	BR-223	1	1994+
1	Rear Gauge Roller 1 7/16" Shafts	SC174	BR-203A	1	1994+
1	Rear Gauge Roller 1 7/16" Shafts	SC188	BR-204A	1	1994+
1	Rear Gauge Roller 1 7/16" Shafts	SC1100	BR-205A	1	1994+
1	Rear Gauge Roller 1 7/16" Shafts	SC1120	BR-220	1	1994+
2	Bearing Assembly 1 7/16" 2 Bolt	All	BR-2400	2	1994+
3	Height Adjusting Plate	All	BR-208A	2	1994+
4	Skid Shoe Right Side	All	S-225	1	1994+
4	Skid Shoe Left Side	All	S-226	1	1994+
5	Rubber Belting (Per ft.)	All	RB-1700	A/R	1994+
6	Belt Clamping Strip (Per ft.)	All	RB-1701	A/R	1994+
7	Self Tapping Screws	All	RB-1702	A/R	1994+
8	Lower Lift Arm Hitch Pin	All	TP-242	2	1994+
9	Click Pin (Not Shown)	All	P-791	2	1994+
	Decal Set	All	DC-SC	1	1994+

## Gearbox Assembly

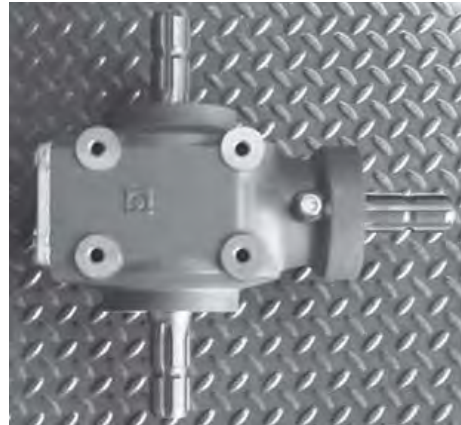
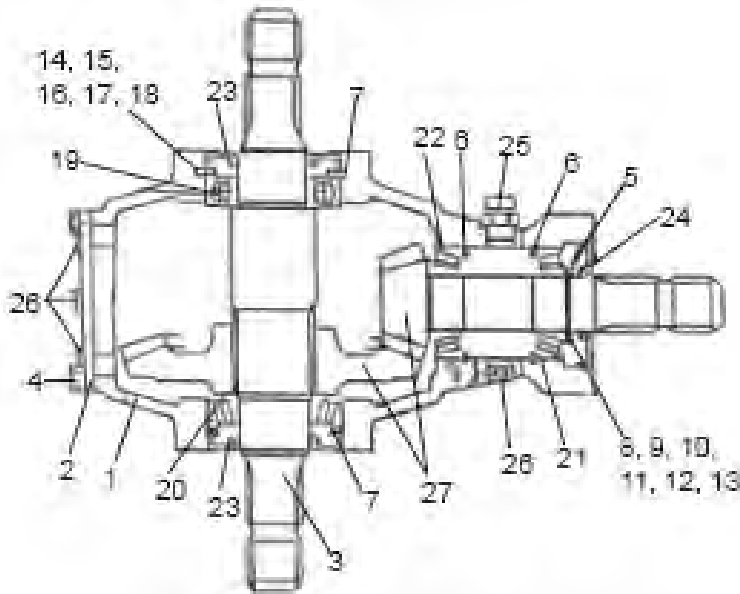

#	Description	Model	Part #	Qty.	Year
1	Main Housing	All	BP-2701	1	1994+
2	Rear Cover	All	BP-2702	1	1994+
3	Input Shaft	All	BP-2703	1	1994+
4	Cap Screw	All	BP-2705	8	1994+
5	Snap Ring	All	BP-2706	1	1994+
6	Snap Ring	All	BP-2707	2	1994+
7	Snap Ring	All	BP-2708	2	1994+
8	Shim Output Shaft 0.5 mm	All	BP-2709	A/R	1994+
9	Shim Output Shaft 0.8 mm	All	BP-2710	A/R	1994+
10	Shim Output Shaft 1.0 mm	All	BP-2711	A/R	1994+
11	Shim Output Shaft 0.3 mm	All	BP-2712	A/R	1994+
12	Shim Output Shaft 0.4 mm	All	BP-2713	A/R	1994+
13	Shim Output Shaft 0.2 mm	All	BP-2714	A/R	1994+
14	Shim Input Shaft 0.6 mm	All	BP-2715	A/R	1994+
15	Shim Input Shaft 0.8 mm	All	BP-2716	A/R	1994+
16	Shim Input Shaft 1.0 mm	All	BP-2717	A/R	1994+
17	Shim Input Shaft 0.3 mm	All	BP-2718	A/R	1994+
18	Shim Input Shaft 0.4 mm	All	BP-2719	A/R	1994+
19	Ball Bearing	All	BP-2720	1	1994+
20	Tapered Bearing Assembly	All	BP-2721	1	1994+
21	Tapered Bearing Assembly	All	BP-2722	1	1994+
22	Tapered Bearing Assembly	All	BP-2723	1	1994+
23	Oil Seal, Input Shaft	All	BP-2724	2	1994+
24	Oil Seal, Output Shaft	All	BP-2725	1	1994+
25	Breather	All	BP-2730	1	1994+
26	Oil Plug	All	BP-2726	4	1994+
27	Ring and Pinion Gear Set	All	BP-2727	1	1994+
28	Safety Cover, Input Shaft	All	BP-2728	1	1994+
29	Safety Cover, Rear Shaft	All	BP-2729	1	1994+
	Complete Gear Box Assembly		BP-2700	1	1994+





Fax Back 24-Hr Parts Order Form

Prices are subject to change without notice. Some parts may require different lengths for model specific applications.

# Parts Order Form-Super Series

Purchase Order Number \_\_\_\_\_

Dealership Name \_\_\_\_\_

Ship to Address \_\_\_\_\_

Contact Person \_\_\_\_\_

Telephone # \_\_\_\_\_ Fax # \_\_\_\_\_

<u>Part Number</u>	<u>Description</u>	<u>Quantity</u>
B-156A	Banded Belt-3 Groove	_____
TS-1306	Bearing Assembly-1 3/8"	_____
BR-2400	Bearing Assembly-1 7/16"	_____
CD-1800	Bearing Assembly-1 15/16"	_____
CD-2110	Scoop Knife	_____
CD-2120	Hanger	_____
CD-2135	Short Link	_____
DC-SC	Decal Set	_____
BP-2700	Gear Box Assembly	_____
BP-2728	Input Shaft Safety Cover	_____
BP-2729	Rear Shaft Safety Cover	_____
IP-145A	Idler Pulley	_____
IP-149	Idler Arm Spring	_____
IP-151	Idler Arm Bearing	_____
IP-152	Idler Bearing Washer	_____
P-131	3 Groove Lower Sheave	_____
P-132	3 Groove Upper Pulley	_____
RB-1700	Vrisimo Belting per ft.	_____
TL-1540	Retainer-1 3/8"	_____
TL-1630	Retainer-1 15/16"	_____
TS-1085	Universal Assembly	_____
SMV1FP-C	Slow Moving Decal	_____
DS-2200	PTO Shaft Assembly	_____
P-791	Click Pin	_____
TP-242	Hitch Pin	_____

**Fax this completed form to (209) 882-9001.**

Vrisimo Equipment  
 P.O. Box 220-2507 Tully Rd.  
 Hughson, CA 95326  
 Phone: (800) 426-5615 Fax: (209) 882-9001