

PARTS BOOK

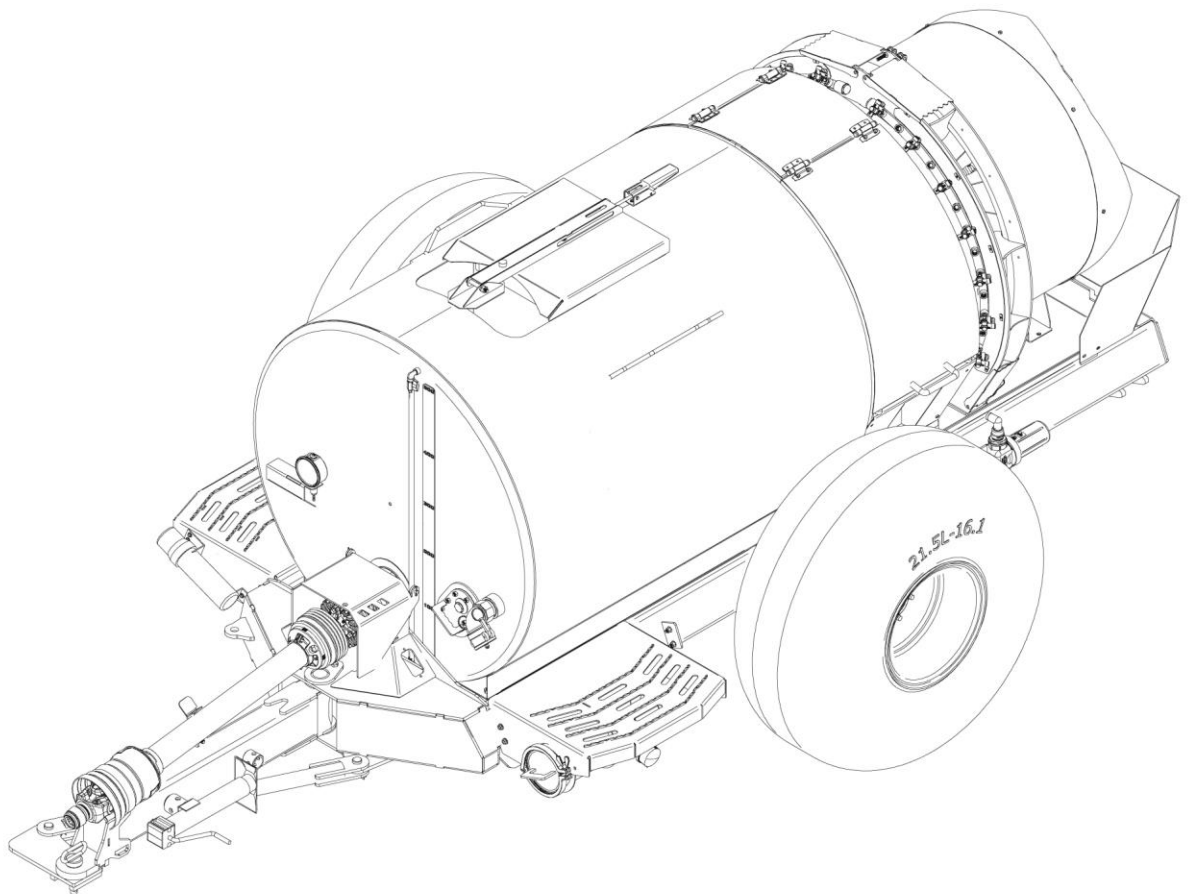

FLOWCORE SPRAYERS



Rev A



Notes:

DWG. NO. **Frame500-600B**

REV **B**

500 Gallon Frame

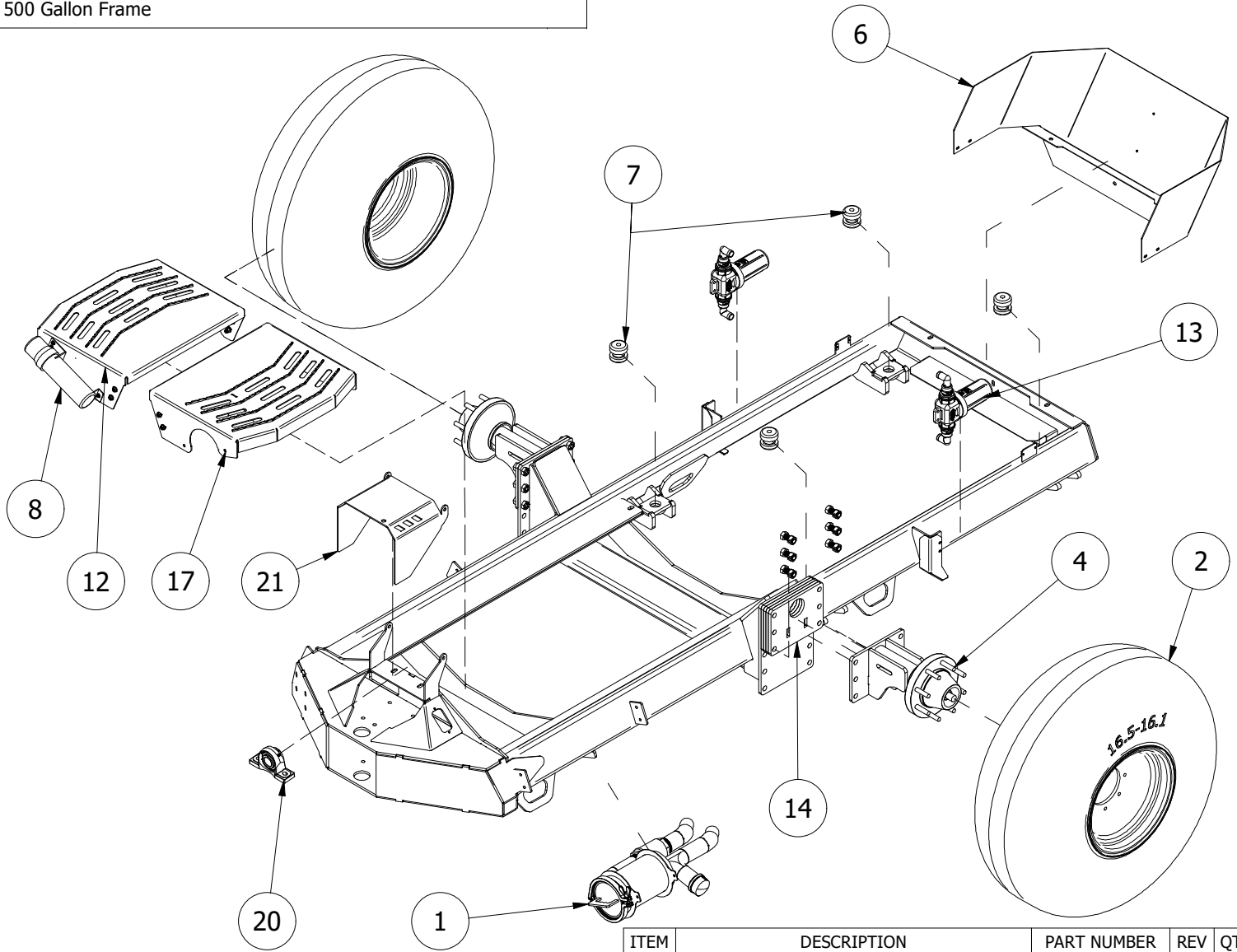

ITEM	DESCRIPTION	PART NUMBER	REV	QTY
1	Quick Release Filter	W00965	A	1
2	WHL + TIRE 16.5-16.1STANDARD 600 GAL	601392	A	2
3	Frame Weldment 500-600 STR/TRN	W02318	A	1
4	Spindle and Hub Weldment	W01180	A	2
5	Rubber Mount Frame Tank	W01278	A	2
6	Fan Leaf Guard	W01259	A	1
7	Barry Controls 22003-13 Vib MT	22003-13	A	4
8	Document Holder- Large	DC-100		1
9	Bolt Assembly	W01722	A	8
10	Bolt Assembly	W01794	A	4
11	Mounting Tab 500 GAL STEP	W01821	A	1
12	Step Left	W02098	A	1
13	Filter Assembly Boom Outlet	W01342	A	1
14	Spindle Mount	W01181	B	4
15	Grip - Step	W02099	B	4
16	MOUNTING TAB FOR STEP	W00616	A	1
17	500-600 Step Right Weldment	W02300	A	1
18	GUARD BOOM STR RH	W02309	A	1
19	GUARD BOOM STR LH	W02310	A	1
20	1-1/2" Bearing	UEP 208-24	A	1
21	PTO GUARD FR BRG CVR	W01768	A	1

DWG. NO. **Fan32Asy**

REV **C**

FAN SUBASY 32 IN

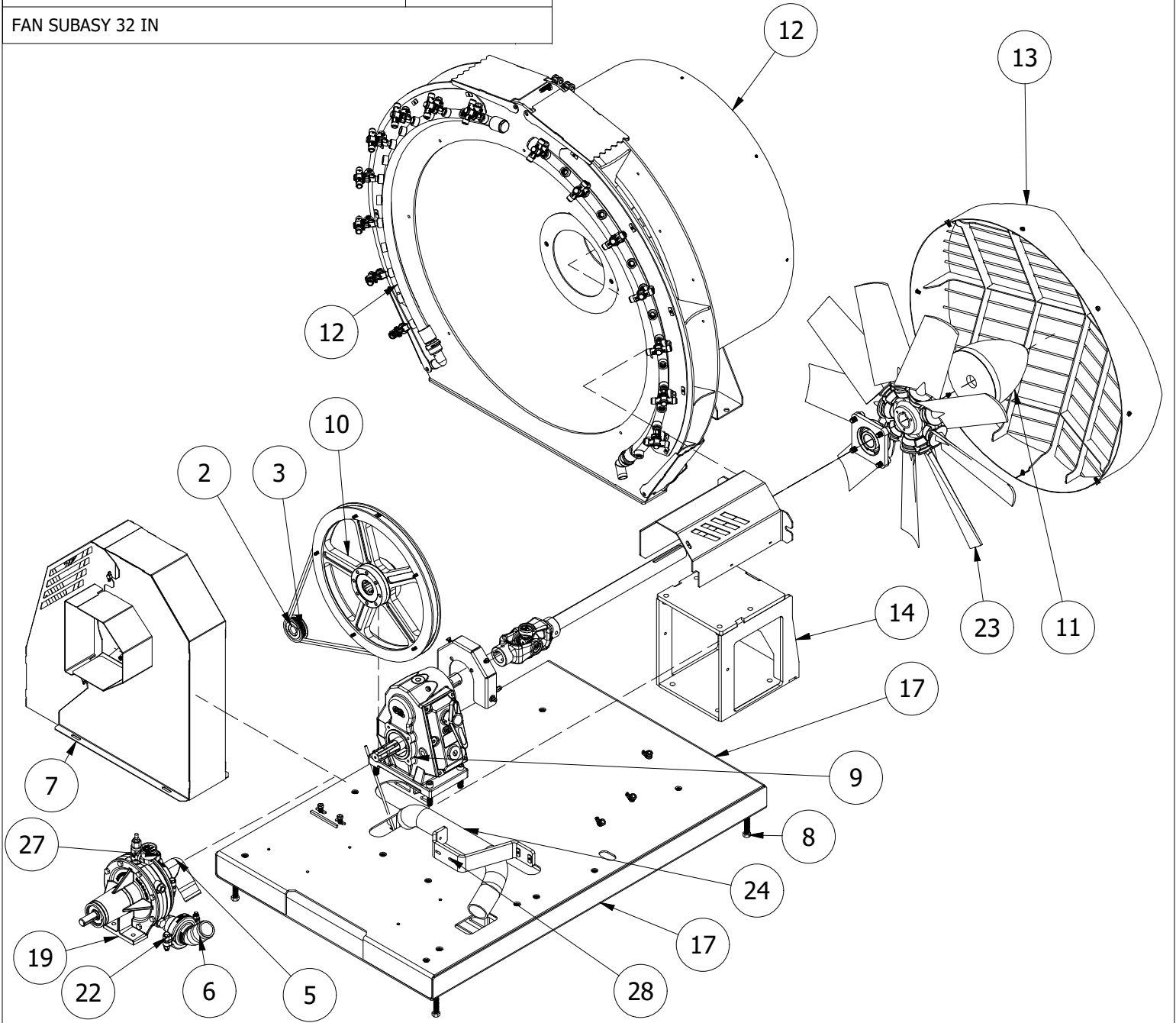

ITEM	DESCRIPTION	PART NUMBER	REV	QTY	ITEM	DESCRIPTION	PART NUMBER	REV	QTY
1	TAPER LOCK BUSHING 1.5	P1X1-1_2	A	1	16	MOUNT FAN GRD BRKT ASY	W01088	A	1
2	Gates 1108.7/8 7858-0114	Gates_1108_7_8	31	1	17	BASE FAN MOUNT ASY	W00885	D	1
3	8MX-25S-12	Gates_8mx_25s_12	16	1	18	SHAFT GRBX TO FAN 40 UJT	W02214	A	1
4	Gates 8MGT-1792-12	Gates_8GTV-1792-12	A	1	19	PUMP ACE FMCWS-650F A-B-D	48934	A	1
5	2" FP FLANGE X 2" HB 90 DEGREE	M220BRB90	000	1	20	SHCS 1/2-13 X 2.5	90128A722	ANY	4
6	2" Manifold Hose Barb x 45 Degree	M200BRB45	000	1	21	BCKNG PLT ASY PUMP MT	W01090	A	1
7	GUARD ASY 2 WTR PMP TO GBX	W02180	A	1	22	V-CLAMP BANJO FC220B	FC220B	A	2
8	HHCS 1/2-13 X 6.5	92865A737	ANY	4	23	Fan 36/9-9/45/PAGST/5ZR/P-1	32-9-9-45-PAGST-5ZR-	A	1
9	GB Gearbox AT55	AT55-3,60-4,00WX0d35	ANY	1	24	1.500/AS	P-1_1.500-AS		
10	SPRKT ASY 2 WTR+FAN DRV	W02211	C	1	25	HOSE 2IN ID T202 CAP RUBBER	2INT202	A	1
11	NOSE CONE ASY	W00715	C	1	26	U-JOINT 1 3/8 SMOOTH X2	TS-1084		1
12	TRPT ASY 32 FAN	W00801	B	1	27	LOOM CLAMP 3/8 ID	3225T230	A	6
13	FAN GUARD 32IN WLDMT1	W00809	B	1	28	PUMP BLEED KIT ACE	W02285	A	1
14	WLDMT SML PDSTL 50HP GRBX	W01094	A	1		Guard & Manifold Support	W02232	A	1
15	SHAFT GUARD LARGE 1	W01086	A	1					

DWG. NO. **W00830**

REV **A**

SPRY BOOM ASY SM

Note: Right Hand Side Boom
Assembly available as W00830R

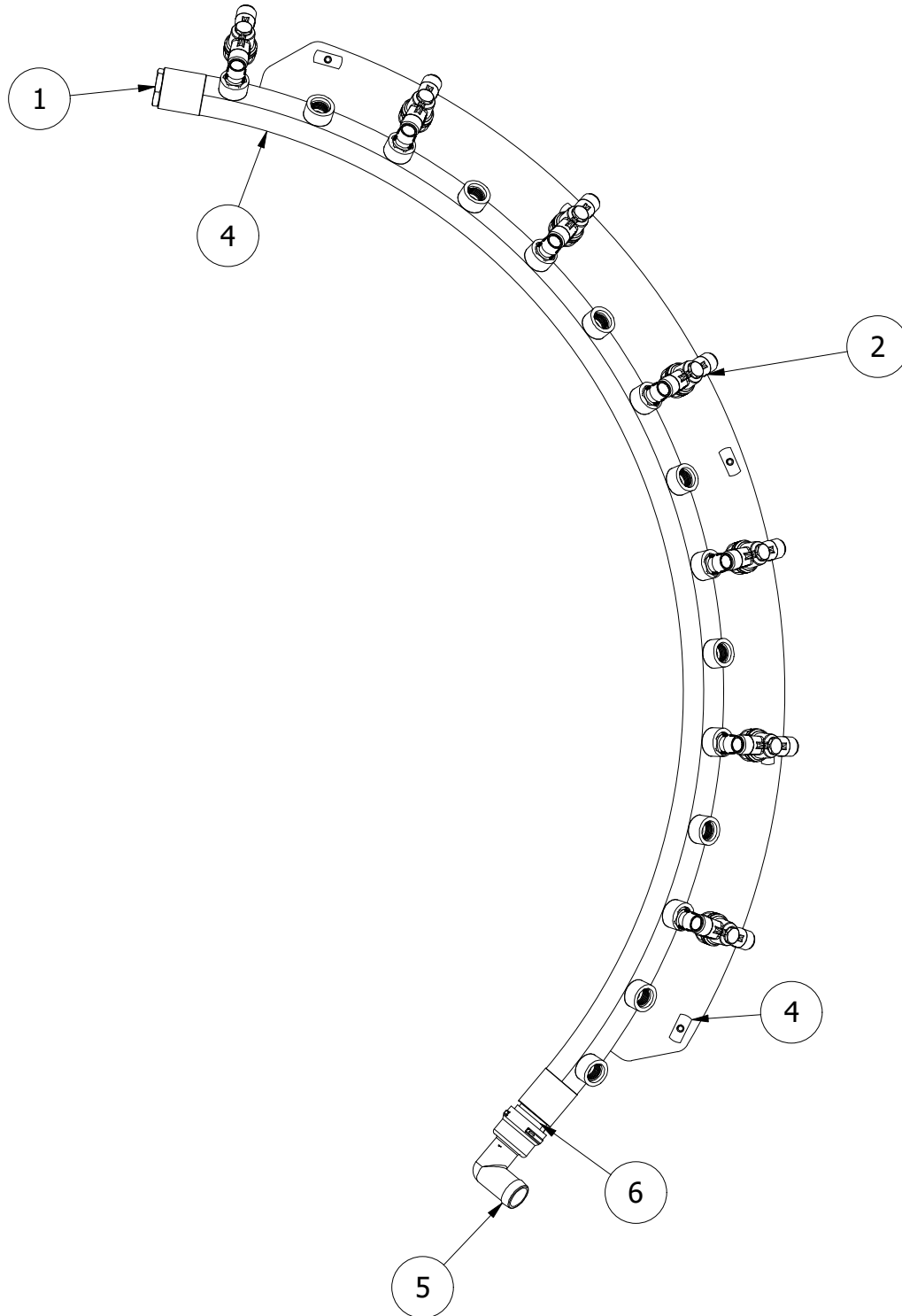

ITEM	DESCRIPTION	PART NUMBER	REV	QTY
1	PLUG 304SS 3/4 NPT	4452K145	ANY	1
2	Double Outlet Rollover (3/8" Inlet)	CM98450-3_8M		7
3	HHCS 1/4-20 X 9/16	92865A173	ANY	5
4	BOOM WLDMT SM	W00831	A	1
5	TEEJET 1INQD X 1IN BARB 90	CMCP45529-90-1	A	1
6	TEEJET 3/4NPT X 1QD	CMCP45527-NYB		1

DWG. NO. **W01822**

REV **A**

MNFLD CTL TEEJET BASE ASY

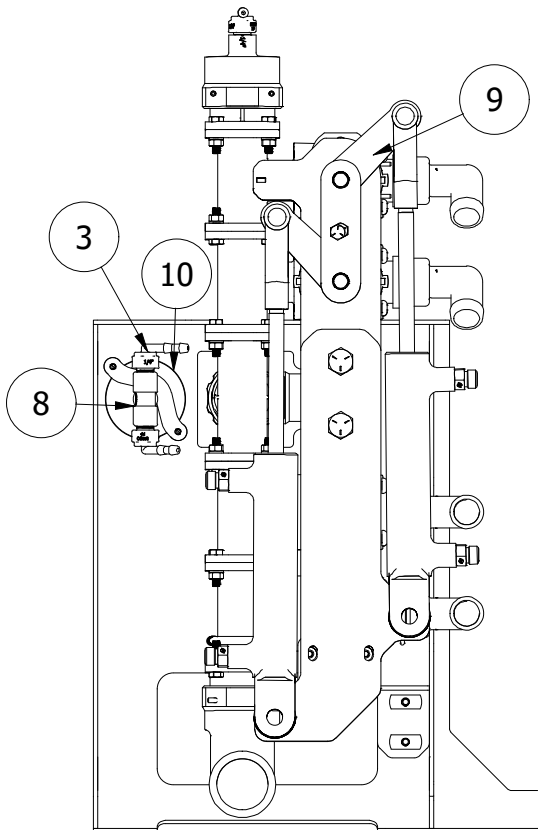
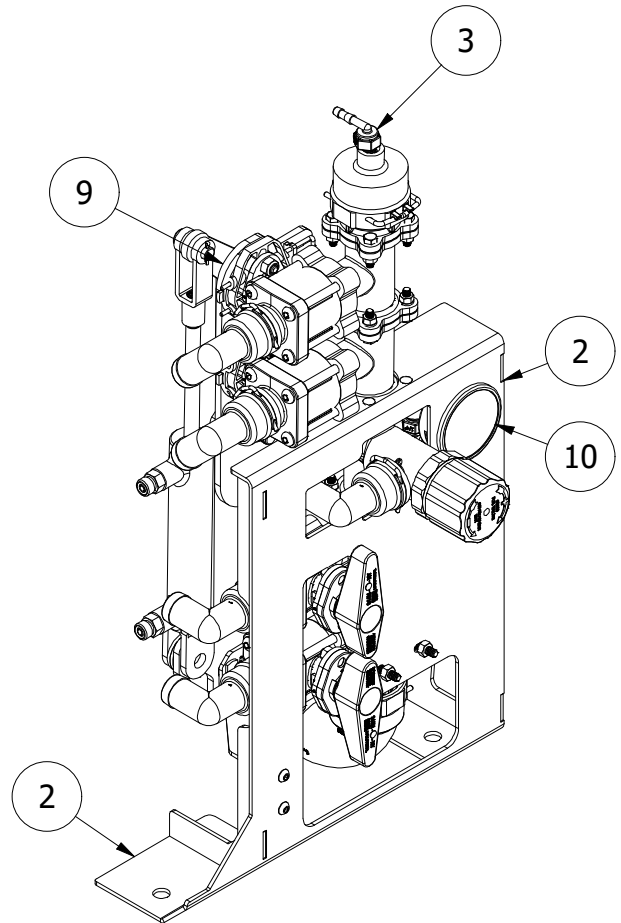
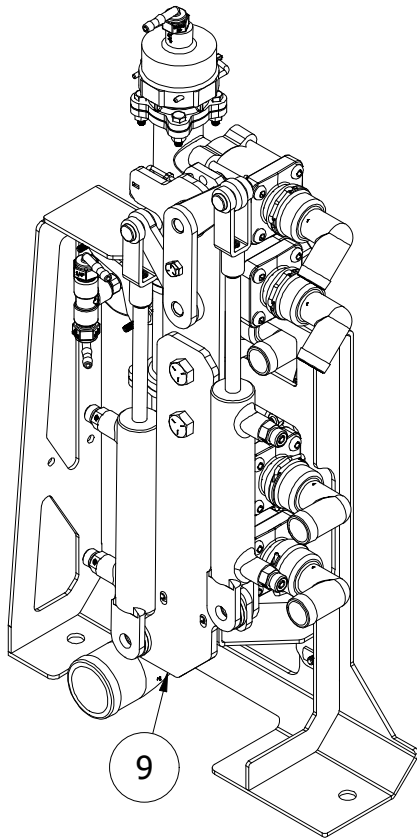

ITEM	DESCRIPTION	PART NUMBER	REV	QTY
1	U-Bolt 1/4"-20 Thread Size, 1-1/2" ID	3043T617	A	1
2	Manifold Mount Asy	W00866	A	1
3	1/4NPT X 1/4" HB BANJO PN HB025-90	HB025-90	A	3
4	Weld Nut, 1/4"-20 TAB	98001A130	A	5
5	HHCS 1/4-20 X 1 IN	92865A542	A	1
6	ZEE BRKT HYD CTRL STFNR	W01826	A	1
7	BHCS 1/4"-20 X 9/16"	91255A524	A	4
8	1/4" TEE BANJO PN TEE025	TEE025	A	1
9	ASY, HYD VALVE ACTUATOR ON/OFF	W01844	A	1
10	Gauge 200PSI 1/4IN NPT	3845K515	A	1
11	VALVE ON/OFF MFD X 1IN QD TEEJET	344BEC-CLIP	A	1
12	VALVE ASY TEEJET HYD CTL	98504-21	A	1

FAN PITCH SELECTION

PTO HP	FAN HP	PITCH	PART NUMBER
69.3	58.9	45	36-9-9-45-PAG-5Z
40.5	34.4	37.5	36-9-9-37.5-PAG-5Z



3.43

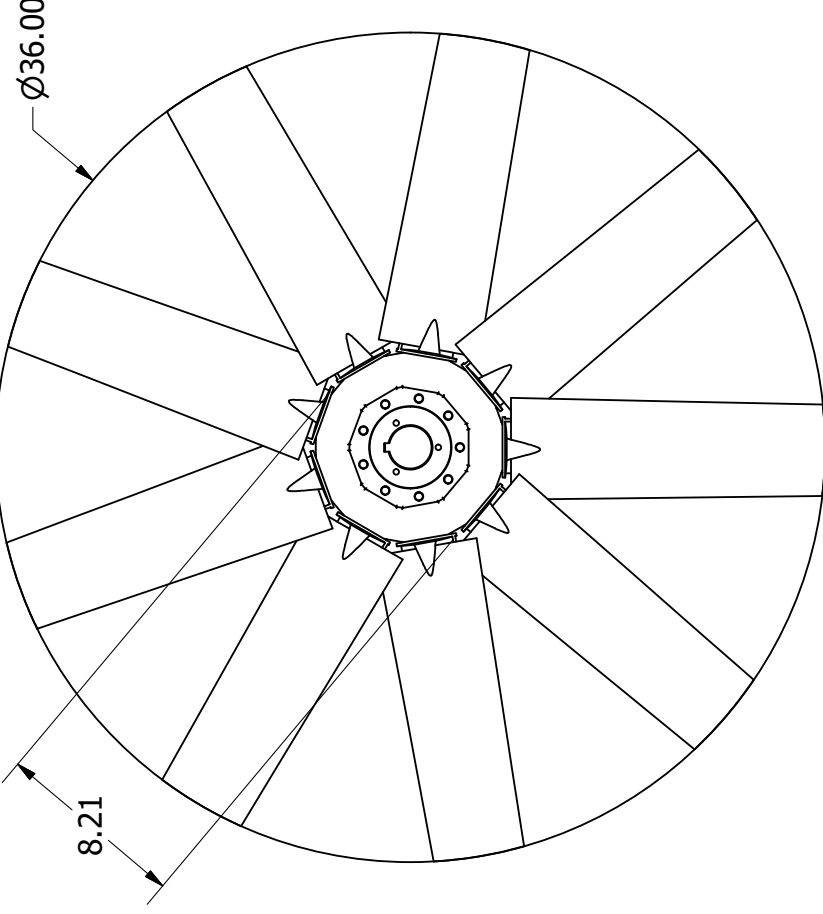
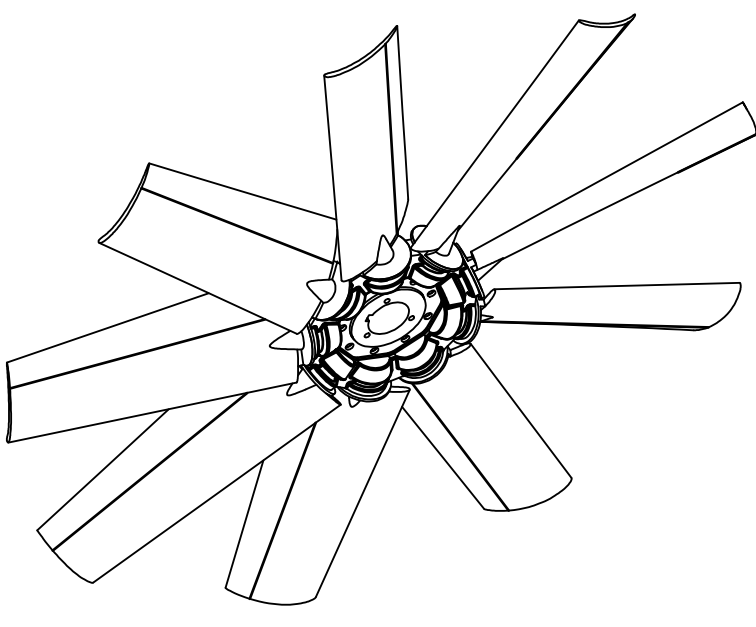

UNLESS OTHERWISE NOTED:
DIMENSIONS ARE IN INCHES
TOLERANCES:
FRACTIONAL .XX .XXX ANGLE
±.1/32 ±.01 ±.005 ±.1
THIS DRAWING IS THE SOLE
PROPERTY OF VALLEY TOOL
MANUFACTURING COMPANY
REPRODUCTION OR
USE IN PART IS STRICTLY
PROHIBITED WITHOUT OUR
WRITTEN CONSENT

REV	DESCRIPTION	DATE	BY
A	INITIAL RELEASE	3/5/20	JF

VALLEY TOOL
MANUFACTURING COMPANY
Product Type:
Buyout
2507 Tully Road
Hughson, CA 95326
Scale: 0.12 : 1
FAN 36IN OD SELECT PITCH
PROJECT: FLOWCORE
DESIGN: JF 12/3/2018 DWG. NO. 36-Fan
DWG: JF 3/5/2020
Sheet 1 of 1
REV A

FAN PITCH SELECTION		
PTO HP	FAN HP	PART NUMBER
31.2	26.5	32-9-9-45-PAG-5Z
48.24	41	32-9-9-37.5-PAG-5Z

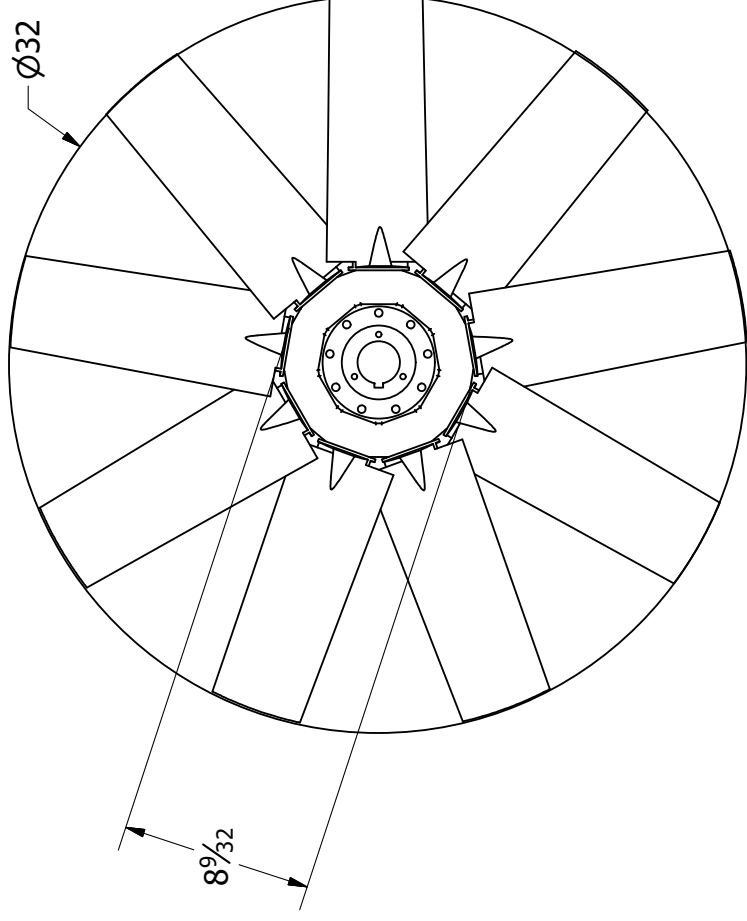
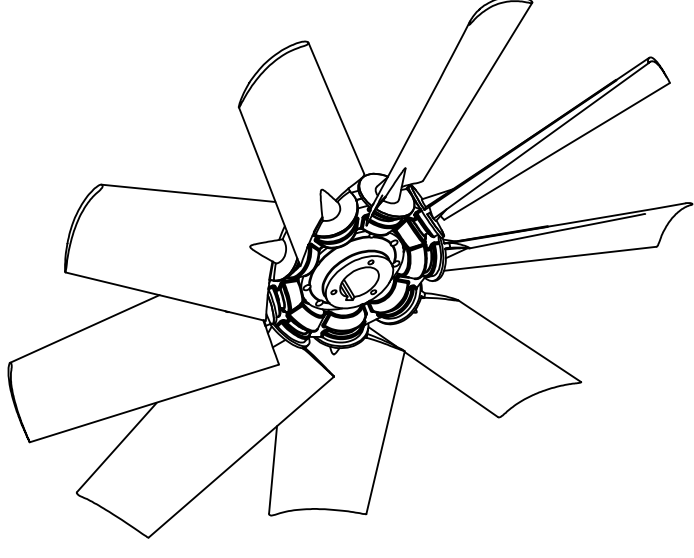

UNLESS OTHERWISE NOTED:
DIMENSIONS ARE IN INCHES

FRAC .XX .XXX ANGLE
±.1/32 ±.01 ±.005 ±.1

THIS DRAWING IS THE SOLE
PROPERTY OF VALLEY TOOL
MANUFACTURING COMPANY
REPRODUCTION OR
COPYING IN ANY MANNER
IS STRICTLY PROHIBITED
WITHOUT OUR
WRITTEN CONSENT

REV	DESCRIPTION	DATE	BY
A	INITIAL RELEASE	3/5/20	JF

VALLEY TOOL
MANUFACTURING COMPANY

Product Type:
Buyout
2507 Tully Road
Hughson, CA 95326
Scale: 0.12 : 1

FAN 32IN OD SELECT PITCH
PROJECT: FLOWCORE
DESIGN: JF 12/3/2018 DWG. NO. 32-Fan
DWG: JF 3/5/2020

Sheet 1 of 1
REV A

FAN PITCH SELECTION

PTO HP	FAN HP	PITCH	PART NUMBER
88.5	75.3	45	40-9-9-45-PAG-5Z
50.8	43.2	37.5	40-9-9-37.5-PAG-5Z

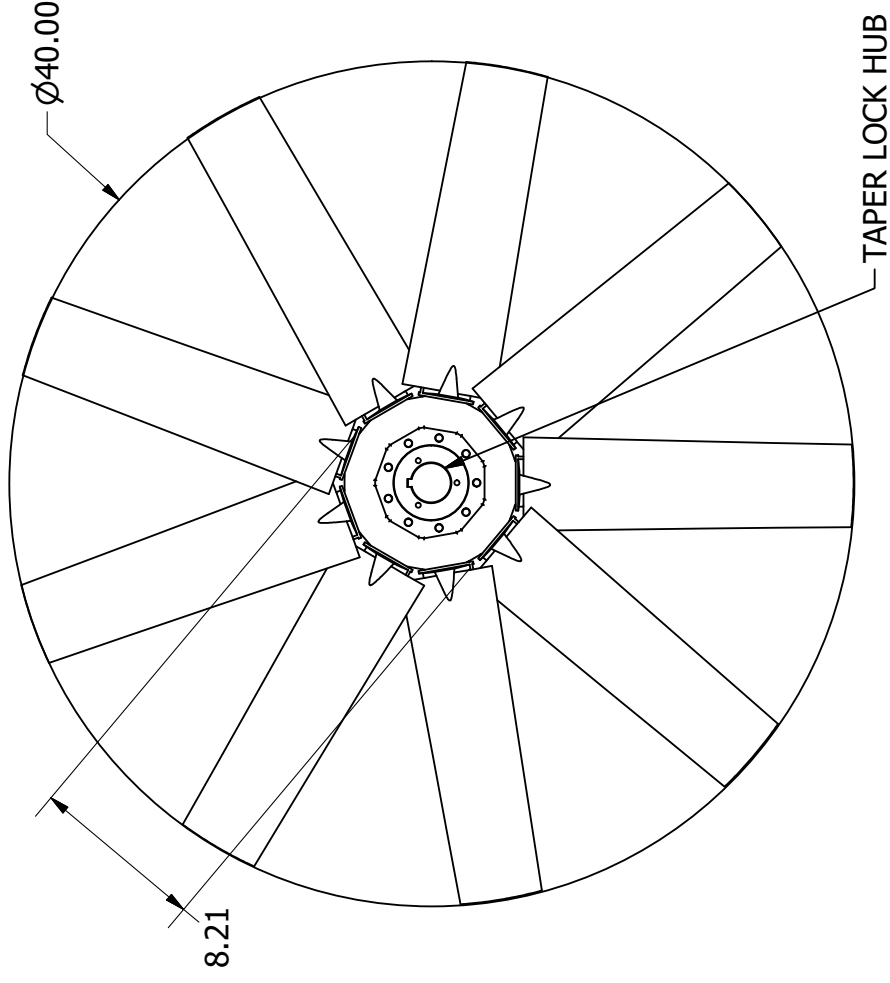
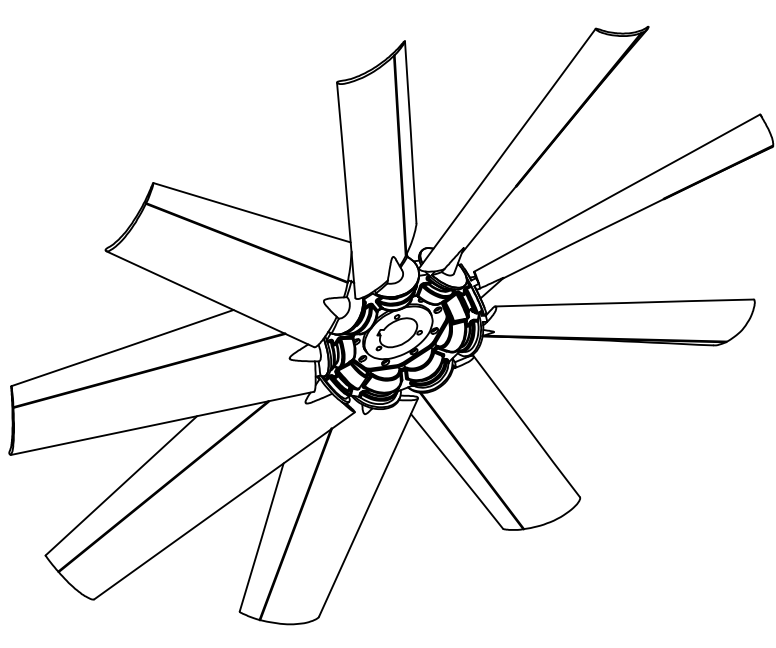

UNLESS OTHERWISE NOTED:
DIMENSIONS ARE IN INCHES

FRAC .XX .XXX ANGLE

$\pm 1/32 \pm .01 \pm .005 \pm .1$

THIS DRAWING IS THE SOLE
PROPERTY OF VALLEY TOOL
MANUFACTURING COMPANY
IN PART IS STRICTLY
PROHIBITED WITHOUT OUR
WRITTEN CONSENT

REV	DESCRIPTION	DATE	BY
A	INITIAL RELEASE	3/5/20	JF

VALLEY TOOL
MANUFACTURING COMPANY

Product Type:
Buyout
2507 Tully Road
Hughson, CA 95326
Scale: 0.11 : 1

FAN 40IN OD SELECT PITCH

PROJECT: FLOWCORE

DESIGN: JF 12/3/2018 DWG. NO. FCFAN-40

DWG: JF 3/5/2020

Sheet 1 of 1

REV A

