

FX36 Defender
Forestry Mulcher
Owners Manual



FX36 DEFENDER OWNER'S MANUAL



VALLEY TOOL
MANUFACTURING COMPANY

PO Box 220 | 2507 Tully Road | Hughson, CA 95326 | 800-426-5615
www.valleytoolmfg.com



Table Of Contents

Introduction

Thank You	1
Warranty	2

Safety

Operational Safety	3-4
Maintenance Safety	4

Basic Operation

Transport / Storage	5
Attaching to Power Unit / Removal from Power Unit	5-6
Starting / Shut Down / Running	7-8
General Guidelines	9

Adjustments & Maintenance

Lubrication	10
Wearable Components	11
Knife Maintenance	11-12
Bush Bar Adjustment	12
Cleaning Attachment	13
Hydraulics Maintenance	14

Parts Book

Top Level Assembly	16
Motor Plumbing	17
Tool Holder	18
Cutter Drum	19
Recutter Door	20
Guards	21

Thank You

Dear Customer,

We appreciate your purchase of a BrushHound attachment. The purpose of this manual is to familiarize you with the operation, adjustment, and maintenance of your new attachment. It was meticulously designed and constructed in accordance with the highest industry standards to provide you with years of dependable service. Before endeavoring to operate the machine, you must read this manual thoroughly and comprehend its operation. BrushHound reserves the right to make modifications to design and specifications, as well as additions and enhancements to its product, without incurring any obligation to retrofit previously manufactured items. If you ever require additional information, please contact your authorized dealer or customer service.

BrushHound designed this attachment with operator safety as one of its primary considerations. This attachment was designed with shielding, simple adjustments, and other safety features whenever practicable. Ensure that you and your employees read and comprehend this manual. Only responsible individuals who have been trained to operate in a secure manner and who have read and comprehend this manual should operate any machinery.

Before accepting the equipment, verify the pre-delivery checklist thoroughly with the sales representative. See pg.5

Ensure that all operators have a comprehensive understanding of the operation, adjustment, and safety principles outlines in this manual.

BrushHound Attachments is solely owned by Valley Tool and Manufacturing.

Visit: www.valleytoolmfg.com



PO Box 220 | 2507 Tully Road | Hughson, CA 95326
1-800-426-5615
www.valleytoolmfg.com

Product Registration



Valley Tool & Mfg. warrants each product to be free of manufacturing defects for a period of twelve months (ninety days for rental units) from the date of delivery to the original user/owner, subject to the limitations stated in this policy.

This warranty does not apply to defects caused in whole or in part by unreasonable use while the product is in the user's possession, including but not limited to: failure to properly set up product; failure to provide reasonable and necessary maintenance; normal wear; routine tune-ups or adjustments; improper handling or accidents; operation at speed or load conditions contrary to published specifications; improper or insufficient lubrication; improper storage. This warranty also does not guarantee that the efficacy of every product will meet the purchaser's expectations.

Valley Tool & Mfg. shall not be liable for consequential damages of any kind, including, but not limited to, consequential labor costs or transportation charges associated with the replacement or repair of defective parts; lost time or expenses incurred as a result of said defects. Valley Tool & Mfg.'s total liability is limited to the purchase price of the product.

Valley Tool & Mfg. provides no warranty for trade accessories or any component or accessory of the product that was not manufactured by Valley Tool & Mfg., including any purchased components. These are subject to the respective manufacturer's warranties. If the product or any part of the product is modified or repaired in any manner not expressly authorized by Valley Tool & Mfg., or if closed components are disassembled prior to return, the warranty will be void. Closed components include gearboxes, hydraulic pumps, motors, cylinders, and actuators, among others.

Our obligation under the warranty is expressly limited, at our option, to the replacement or repair at Valley Tool & Mfg., of Hughson, California, or at a service facility specified by us, of the defective part or parts as determined by inspection.

We are not liable for unauthorized replacements or repairs. Warranty pre-approval is required. Authorized supplies will be sent to the dealer at no cost via UPS Ground. The duration of any implied or statutory warranties, such as warranties of merchantability or fitness for a particular purpose, is expressly limited to the duration of this written warranty. No one is authorized to make any other express or implied warranties on our behalf. This warranty cannot be extended, expanded, or altered unless authorized in writing by Valley Tool & Mfg. No warranty will be processed without a timely, signed "Product Registration"

The attachment owner is responsible for the travel time of mechanics and conveyance of the product to the authorized service dealer for warranty work.

The most reasonable and dealer-friendly return policy on the market is provided by Valley Tool & Mfg. The return policies for each of our brands are listed below. We accept returns within 30 days of the date of original shipment. Prior to return shipment, all returns must be approved by Valley Tool & Mfg, and a return authorization number must be issued. Returns must be in "like-new" condition and accompanied by all original factory packaging, including instruction manuals. If an item is received that is not in "like-new" condition or in its original packaging, additional fees will apply. After our staff has completed a thorough inspection of a return, refunds will be issued less shipping fees and any other potential damage fees. Please allow up to 30 business days for the processing of your account refund credit.

Please direct all return-related questions to sales@valleytoolmfg.com.

Safety

Safety messages are provided in this manual to describe possible risk during operation, maintenance and transportation. These messages are intended to convey known hazards but cannot be construed to describe all possible risks.

Signal words in Safety Messages:

DANGER

Danger: Indicates immediate risk of serious injury or death.

WARNING

Warning: Indicates possibility of serious injury or death.

CAUTION

Caution: Indicates possibility of minor injury.

NOTICE

Notice: Indicates possibility of property damage, possible machine failure but no immediate risk to personal injury.

Failure to heed any of these warnings may result in personal injury or death.

Operational Safety

Before operating this machinery read the owner's manual thoroughly. Properly train all Operators. It is the Owner's responsibility to ensure all Operators are properly trained in the appropriate language. Use OSHA approved eye, ear and head protection to protect the Operator from flying debris and noise. Never use drugs or alcohol before or during operation of this machine. Only operate this machine when it is in good working order on an appropriate power unit that is in good working order, and with all guards and safety devices in place and functioning. Never allow children or other people to ride on this machine.

DANGER

Keep bystanders and children of the clear work area during operation as debris can be discharged and cause serious injury or death. Maintain a minimum distance of 300 ft.

DANGER



300 FT
↔



DANGER

Risk of death or injury if moving parts are touched, or are brought into contact with any person. Keep away from all moving parts. Keep guards in place while operating.

Operate only with clear visibility, never in dusty, foggy conditions or at night. Risk of collision or contact with personnel. Crushing, piercing or cutting hazard.

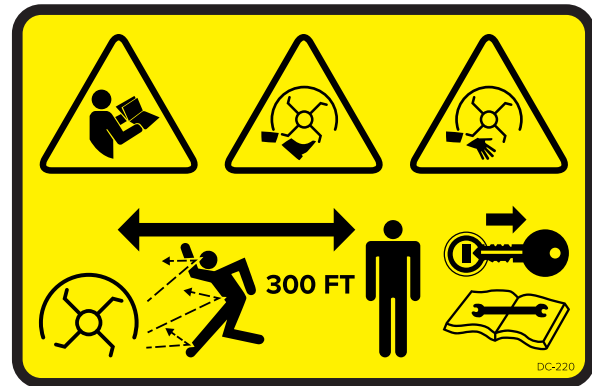

WARNING

Avoid operation that would allow hydraulic lines to be pinched or severed. In the event of a hydraulic leak, hydraulic fluid may have sufficient force to penetrate skin. Do not use any body part to check for leaks. High pressure oil can cause severe injury or death.

Disengage hydraulics, shut off engine and allow all movement to stop before leaving the operator's position to adjust, lubricate, clean or unclog the machine. Do not try to uncouple hydraulic hoses unless the pressure has adequately dissipated.

Risk of serious injury or death due to thrown debris or broken knives. Do not operate closer than 300 ft to people, unprotected roadways or public areas without properly securing or warning protecting against accidental ingress. Risk of fire due to knife contact with stones, concrete, steel or other hard objects. Sparks can ignite dry grass, wood chips or other flammable material. Do not operate in dry grass, severe fire risk areas or in an area actively burning or recently burned. Consult local requirements around operation during Fire Weather Watch or Red Flag Warning conditions.

CAUTION

Rotating parts, Hydraulic hoses, motors and valves generate heat when operating. Do not touch when hot. Allow to cool before maintaining.

Risk of crushing, pinching or cutting due to motion of machine while maintaining. Ensure all energy is dissipated from hydraulic lines before maintaining. Secure power unit and attachment against motion with wheel chocks, or appropriately sized stands as required.

Remove key from power unit and read manual before maintaining. Risk of accidental motion if key is engaged on power unit. Knives wear parts and damaged components can have sharp edges that cause cuts or lacerations. Wear protective gear and handle these parts with care.

CAUTION



Basic Operation

Pre-Delivery Checklist

- Check all nuts and bolts for correct torque.
- Check for shipping damage. If damaged, do not use the attachment until parts have been replaced or repaired.
- Check that all hydraulic hoses and fittings are tight.
- Check that all warning signs (decals) and safety treads are on the attachment and in their correct location. Replace any damaged signs or safety treads.

Review all safety information outlined in safety section of manual before proceeding with any operation of attachment.

Storage

1. Storage Between Jobs

- Clean the attachment thoroughly (see Cleaning the Attachment, Pg. 13).
- Lubricate the Attachment as recommended (See Lubrication section for lubrication details Pg10).
- Check wear parts and replace as necessary.
- Store in clean, dry place.

2. Storage On Power Unit

When leaving the Attachment unattended while still attached to the Power Unit:

- Find a suitable, flat location to leave the Power Unit and Attachment.
- Lower the Attachment to the ground after disengaging the auxiliary hydraulic circuit. Make sure both ends rest securely to prevent tipping when disconnected.
- Turn off Power Unit and remove ignition key. Wait for drum to completely stop rotating before leaving unattended.

NOTICE

This BrushHound attachment was custom matched to the power unit specified at purchase. Although it may fit various machines, it is designed to work only with power units that share the same mount and hydraulic specifications. Connecting to a different unit can cause damage. If another power unit must be used, contact a BrushHound dealer first.

The individual handling this BrushHound attachment should have experience with safely attaching and detaching standard buckets from backhoes and excavators. Always perform the attachment on flat ground, free from pinch points and blades to avoid injury, and make sure hoses are clear of the mounting plate during process.

Transporting Attachment

- When transporting attachment separate from Power Unit, secure using straps or chains rated for the placed weight. Keep both skid shoes fully supported flat feet and level.



Attaching to Power Unit

- Secure the correct mount for the Power Unit to the BrushHound product using the four 1in bolts provided.
- Position the Power Unit's arm and fasten the mount just like a bucket.
- Link the Attachment's hydraulic lines to the auxiliary circuit of the Power Unit. If the Power Unit lacks this circuit, pull the thumb all the way back and utilize the thumb hydraulic circuit. For specifics on hose connections to the Power Unit, refer to the "Hydraulic Plumbing" section.
- Ensure all connections are tight and quick couplers are fully engaged.

Required: Pressure, Return, Case Drain.

- Set the Power Unit to the "Hydraulic Breaker Mode" (one-way flow).

NOTICE

Operation without case drain will result in motor failure.



Case Drain

Pressure

Return

Removal from Power Unit

- Choose a stable, level area to place the Attachment, ensuring it remains upright.
- Turn off the auxiliary hydraulic circuit and gently lower the Attachment until it touches the ground. Both front and back skid shoes should be in contact with the ground.
- Allow the drum to come to a complete stop and wait for the hydraulic system to depressurize before getting close to the attachment.
- Release the locking mechanisms on the mount of the Power Unit.
- Elevate the boom to separate it from the Attachment.

⚠ WARNING

Risk of crushing injury. Secure against movement.

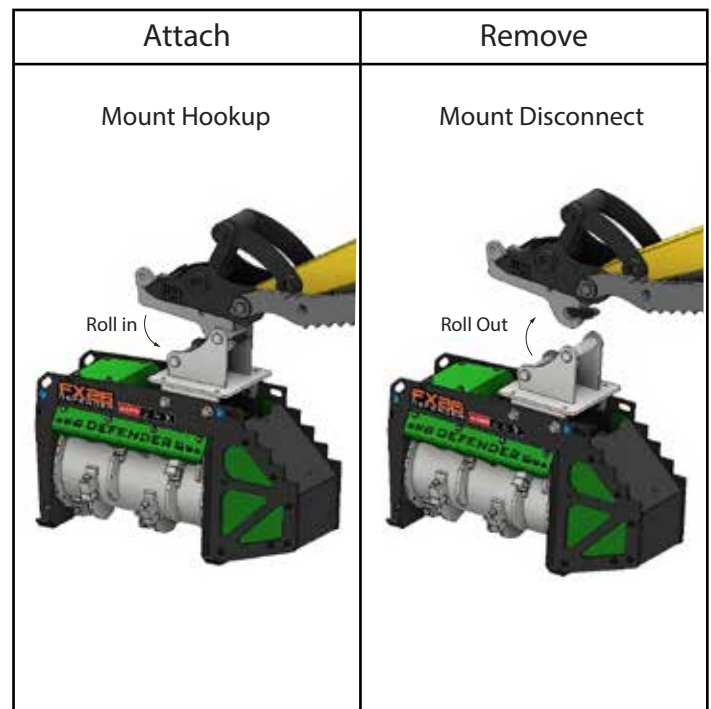

Basic Operation

⚠ CAUTION

The operator using this BrushHound attachment should have proper training and wear appropriate safety gear. Before starting the power unit, ensure the attachment is correctly assembled and installed, including mount and hydraulic connections, and that all safety devices on both the power unit and attachment are functioning properly. Keep the work area clear of bystanders and children.

⚠ CAUTION

Avoid touching hot or sharp areas with bare skin, as they can cause injury. Never check for hydraulic leaks with hands, as the fluid pressure can pierce the skin, necessitating immediate medical attention. Use a piece of cardboard or paper to check any suspected leak.

NOTICE

FX Series attachments are crafted to handle a variety of vegetation, from grass and dense brush to medium-sized trees. To achieve optimal results, assess the state of the land and vegetation to be cut. When using this tool, always introduce larger branches or dense brush into the attachment's side where the blades strike downwards (the inlet side).



Starting Procedure

- Check that the attachment is in the down position and that the blades are not in contact with the ground. Start engine and set throttle to idle. Never engage above idle speed.
- Ensure Power Unit is set to the “Hydraulic Breaker Mode” (one-way flow). With the engine at low RPM engage the auxiliary hydraulic flow.
- Slowly bring the throttle up to maximum flow. If the Attachment produces excessive noise or vibration, disengage the auxiliary hydraulics and shut down the Power Unit immediately. Determine the cause of the problem and correct it before continuing with its operation.

Attachment is ready for operation.

Shut Down Procedure

- Disengage the auxiliary hydraulics and prepare the attachment for storage or transport (refer to the “Storage and Transport” section for proper storage instructions Pg5). Turn off the power unit, set the parking brake, and wait for the attachment to stop rotating. Allow the hydraulic circuits to release pressure back to the reservoir, as they can remain pressurized even when turned off. Only approach or let others approach the attachment when it's safe to do so.
- Inspect the hydraulic motor, motor protection valve, and other areas visually for signs of excessive heat, debris, build-up, or leaks.

Running The Attachment

1. House Rotation Shredding Technique

This technique is for working with lighter brush on mostly level terrain.

- Move the house control from side to side, keeping the cutter head just above the ground.
- With the Power Unit stationary, rotate the housing to let the attachment glide over the ground, maintaining the chosen cutting height.
- After clearing a section, advance the Power Unit forward.
- Make sure to leave sufficient gap between the edge of the vegetation and the housing for clear visibility.
- Resume the cutting process.

For denser brush, make multiple passes or move at a slower pace, especially if performance seems to decrease.



House Rotation Shredding

2. Top Down Shredding Technique

This method is ideal for thicker brush and trees.

- Begin from a stationary position.
- Elevate the boom and angle the head so its almost perpendicular to the tree. Ensure the knives aren't visible to avoid ejecting material at the cab/operator.
- If the tree's height exceeds the boom's reach and is relatively thin at its tallest point, the FX Series is designed to cut into the tree from the inlet side. This helps in trimming the tree top.
- Once the tree top is removed, start working downwards.
- Use a side-to-side sweeping motion if needed, grinding the stump until it's level with the ground. Avoid contact with ground.
- Shred any debris that might have fallen from the tree during the process. This eliminates the need for manual cleanup by crews.

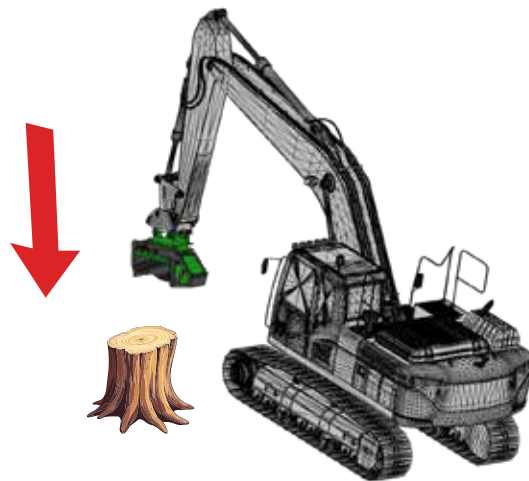

Top Down Tree Shredding

Basic Operation

DANGER

Knife failure can injure or kill.

CAUTION

Never permit bystanders to be close to the mowing or brush cutting operations, nor allow them to climb on the machine.

NOTICE

Avoid using this attachment as bucket for digging up roots or spreading piles of dirt. Such misuse can cause damage that is not covered by the warranty, and repairs may be costly.

Basic Guidelines

This attachment operates most efficiently when the knives are sharp and rotating at full RPM. The recommended shaft speed for this unit is 1700-2200 RPM.

Before starting a job, inspect the work area and remove any hidden hazards, such as large rocks, utility lines, fencing, and concealed debris like broken glass or bottles. Projected debris may pose risks to operators, pedestrians, livestock, or cause property damage, so it is crucial to ensure the area is clear prior to commencing work.

During the work area inspection, watch for bees, fire ants, poison ivy, or poison oak. Additionally, be mindful of unsuitable working conditions, like overly saturated grounds that can create slippery conditions. Identifying potential hazards in the area will not only improve productivity but also enhance safety.

Overloading or “lugging down” the cutter can significantly reduce its cutting capacity and cause an increase in hydraulic oil temperature. Pay attention to the cutter drum speed, and lift it out of the cut until maximum speed is regained before resuming the operation.

Do not operate the attachment unless the safety guards are securely fastened in place.

Abuse may be indicated by drum damage or premature knife failure. To prevent abuse, always reduce the cutting load before the cutter drum speed drops significantly.

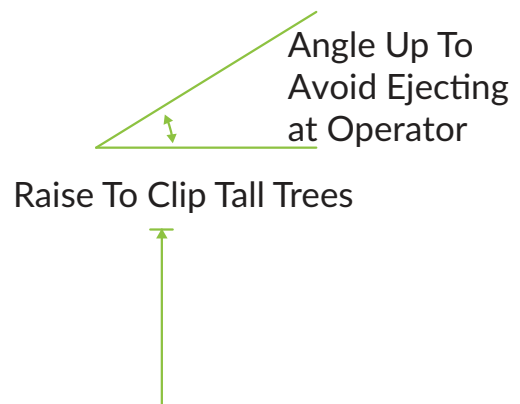
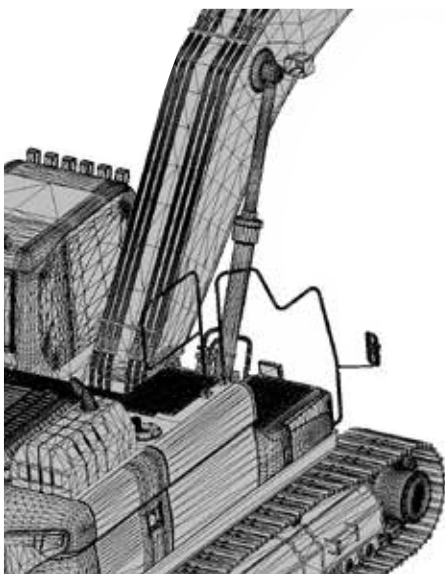

Adjustments & Maintenance

NOTICE

Before proceeding with any adjustments or maintenance, review all safety information provided in the safety section of the manual to ensure proper procedures are followed.

Lubrication

The FX Series included two lubrication points, identified by a blue sticker (DC-234) (50Hrs) grease fittings. Use only BrushHound-approved grease or a compatible grease with similar specifications and EP additives. Bearings use **NLGI grade 2 460** grease. When grease escapes from the bearing seals, this suggests excessive greasing. Expelled black grease with a burnt smell could indicate a history of over-greasing.

Procedure	10HR Daily	50HR Weekly	300 Hours
Knives	Inspect		Rotate/Replace
Bearings	Inspect	Grease	
Hoses	Inspect		
Guards	Inspect		Check Bolt Torque



Any selection from this **Blue Group** of greases are equivalent

Grease Comparison

NAME	NLGI GRADE	KINEMATIC VISCOSITY cSt	
		TEMP DEG C	TEMP DEG C
		40	100
SCHAEFFER 228	2	555	36.5
PH66 MULTIPLEX FS460	1.5	460	
MOBILITH SHC460	2	460	
SHELL GADUS S3 V460D 2	2	460	
MYSTIK JT-6 SYNTHETIC 460	2	460	59.1
MYSTIK JT-6 MULTIPURPOSE	2	460	59.1
PH66 MULTIPLEX 460	2	415	26.8

1. Idle Bearing

The idle bearing can be found beneath the Idle Side Bearing Cover, equipped with a grease fitting on the mounting flange. It's factory filled with premium grease. Apply 1 pump of grease every 50 hours.

If bearing are frequently exposed to wet conditions, more frequent greasing may be necessary. Do not use Molybdenum grease.

2. House Drive Bearings

The motor spindle has a set of 2 angular contact bearings in a housing on the drive shaft with a grease fitting located on the side cover. The housing comes pre-packed with high quality grease and requires. Apply 1 pump of grease every 50 hours. If the motor is removed or the bearings changed, the housing should be repacked as follows:

- 50% fill inside bearing
- 100% fill in housing



Adjustments & Maintenance

Wearable Component Maintenance

1. Rubber Isolation Disk

The disk between the drive end plate and bearing housing reduces vibration from the drum and motor. It lasts over 1,000 hours but should be checked regularly and replaced if worn, thin, torn, or when the cutter drum is removed.

NOTICE

Disk failure will cause damage to attachment.

2. Hydraulic Hoses

Inspect hydraulic hoses inside the motor guards regularly. Vibration may cause shifting, so check for wear during routine maintenance to ensure proper function.

3. Bearings

Bearing failure can cause vibration, noise, or drum seizure. Since early signs are hard to detect, replace bearings every 1,500–2,000 hours depending on usage and conditions.

4. Safety Guards

Safety guards protect the operator, bystanders, and property and must never be removed during operation. Keep them in good condition, replace damaged guards, and clean and maintain paint to prevent wear.



CAUTION

Operating without guards in place can expose moving parts or allow debris to be thrown without proper containment. Risk of injury to

5. Safety Decals

Safety decals warn operators and bystanders of hazards. Keep them visible and unobstructed, and replace any that are faded or worn.

Knife Maintenance

The FX series requires sharp knives for optimal mulching performance. Hardened steel knives offer multiple cutting edges for sharpening, rotation, or replacement, with optional carbide blades on some models.

1. Rotating

The standard knife provided features 4 cutting surfaces, permitting up to 3 rotations in the field where replacement parts or sharpening equipment may be unavailable.

NOTICE

Operating with missing knives causes harmful vibrations, resulting in shift, bearing or frame damage.



Adjustments & Maintenance

Knife Maintenance

The FX series is engineered for forestry mulching, making it crucial to maintain sharp knives for optimal cutting efficiency. The standard cutting tool is a hardened steel knife, featuring multiple cutting surfaces for sharpening, rotation, or replacement. Ensuring the knives are sharp and well maintained guarantees top performance.

NOTICE

Operating with missing knives causes harmful vibrations, resulting in shaft, bearing or frame damage.

1. Rotating

The standard knife provided features 4 cutting surfaces, permitting up to 3 rotations in the field where replacement parts or sharpening equipment may be unavailable.

To rotate the knife:

- Loosen the retention bolt.
- First rotation 180°, second rotation 90°, and third rotation at 180°. (See diagram)
- Re-tighten to 150 ft-lbs with a grade 8 bolt.



Take note that the limiter on the knife holder prevents the sharp corner from being centered; this is intentional, as the U-shaped surface is the cutting portion, not the corner.

2. Sharpening

To sharpen the knives in the holder, use a grinder. Align the grinder with the flat V-shaped side and surface the outer edge of the knife. (See diagram).

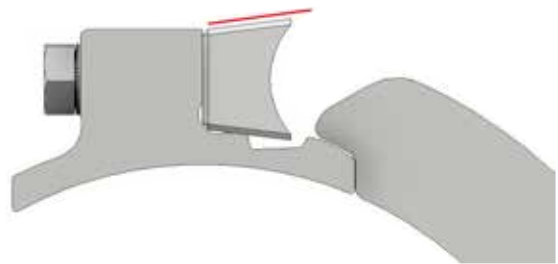

3. Replacing

Remove the knife by unbolting it and replace it with a new one, tightening to 150 ft-lbs using a grade 8 bolt. Use anti-seize on bolt and mating surface of knife. See parts Pg.18 for knife selection.



Adjustments & Maintenance

Cleaning The Attachment

Cleaning the Attachment regularly will help prolong the life of both the paint and the safety decals as well as minimize the risk of unintentional fire.

- Check for excessive grease in the bearing areas, clean off any excess found.
- Clear debris from the hydraulic hose area, bearing area or any other area that may experience heat.
- Clean the inside and top of the Attachment with a pressure washer, removing any accumulated mud, grass or other debris. Mud build up on the cutter drum can cause imbalance.
- Touch up paint where needed to prevent rust.

Optional Mounts

This Attachment is originally manufactured with a mount tailored for the Power Unit. However, to use the Attachment on multiple Power Units, additional units are available to purchase. To attach a mount, align its holes with those on the attachment, then use the 4 supplied 1in bolts, securing them with the included nuts and washers. Before switching Power Units, consult your BrushHound Dealer to ensure compatibility.

NOTICE

Changing Power Units may also require a new motor size.

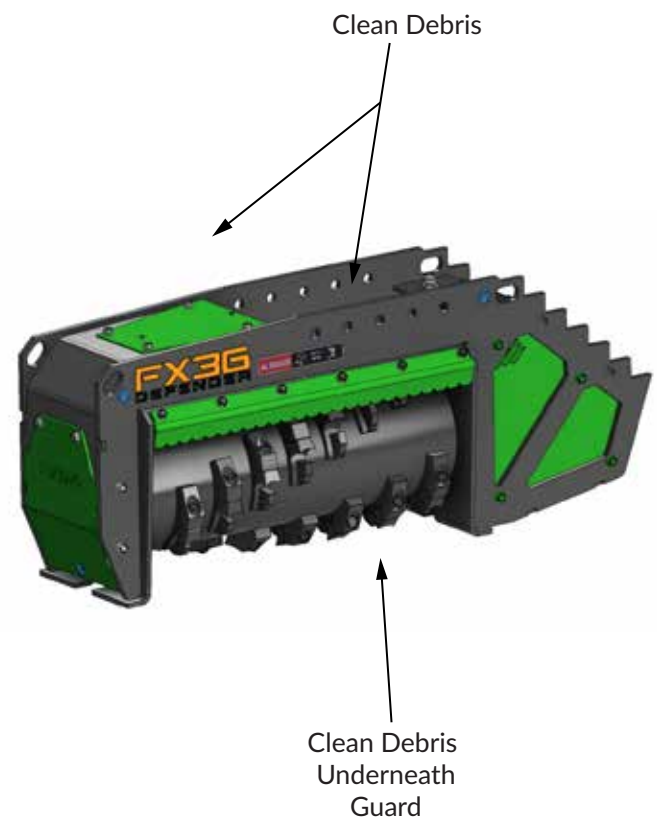

Adjustments & Maintenance

Hydraulic Maintenance

CAUTION

Before performing any maintenance on the hydraulics of this Attachment, ensure that circuit is depressurized. If there is a suspected leak, use a piece of cardboard for inspection. DO NOT use hands to feel for leaks.

The hydraulic circuit should be connected as follows:

- **Pressure In** - This attaches to the Power Unit's high pressure line. On some units it may be necessary to switch the male and female quick connectors to match the Power Unit configuration.
- **Check Valve** - Protects the motor from cavitation that would damage the motor's internal seals by allowing spin down.
- **Supply Line** - Connects the pressure port of the check valve to the pressure port of the motor.
- **Return Line** - The return line should connect the out port side motor port to the relief port of the MPV.
- **Pressure Out (return line out)** - Connect to the return side of the Power Unit hydraulic circuit.
- **Case Drain** is required to protect the shaft seal of the hydraulic motor. Power unit manufacturers offer OEM kits and there are several aftermarket kit available. Consult a local dealer for support.

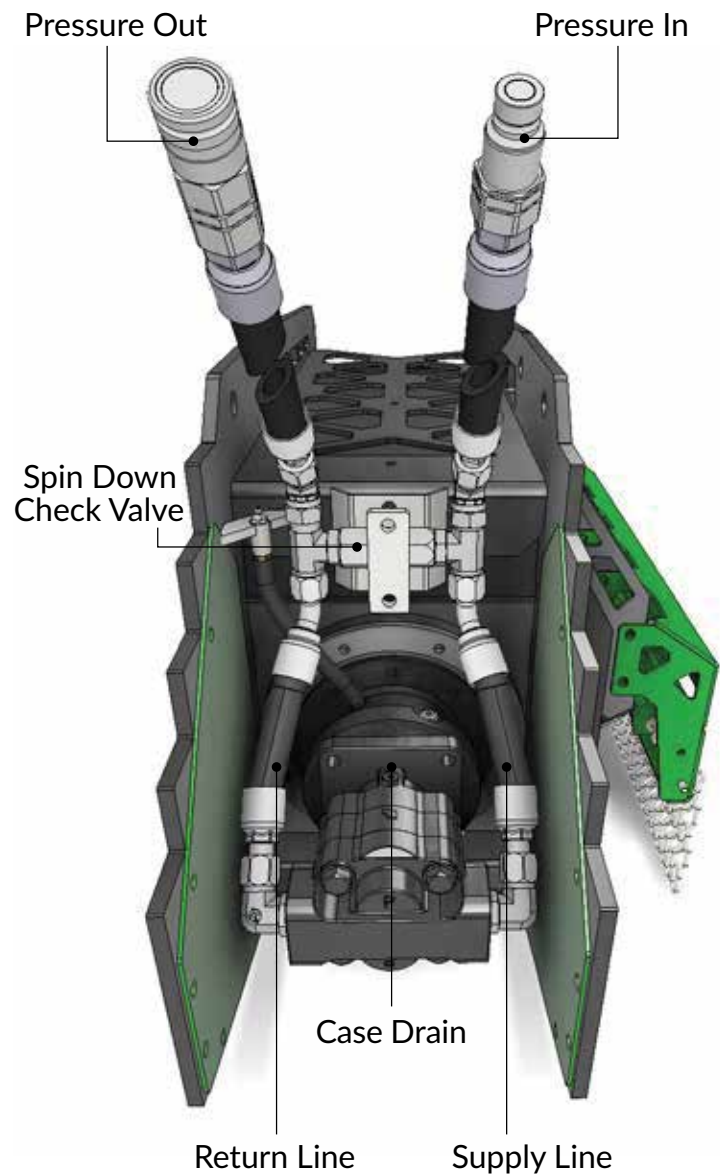

Case Drain Example

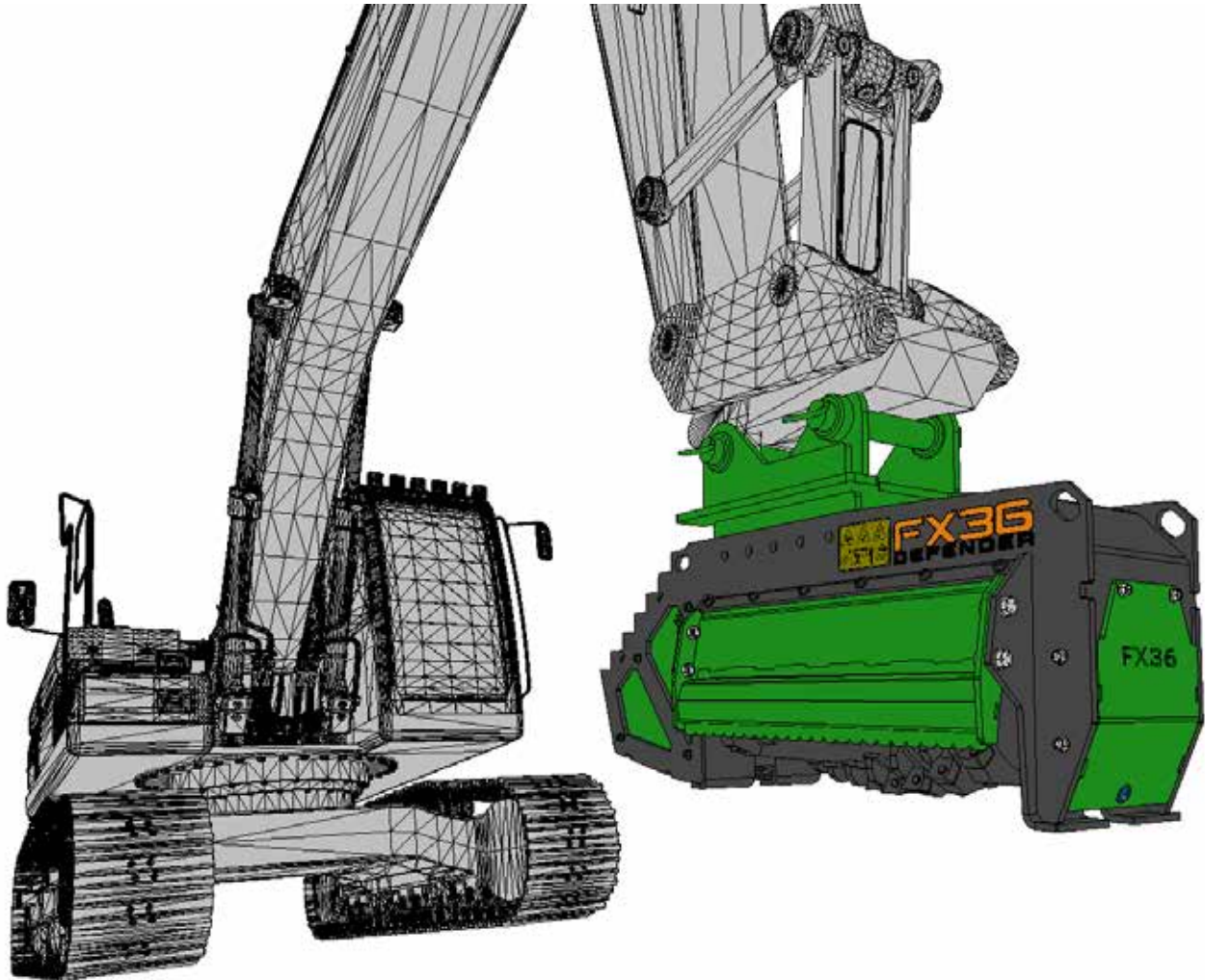

VALLEY TOOL

MANUFACTURING COMPANY

Order Parts Online
shop.valleytoolmfg.com

- Shop OEM Parts
- Fast Shipping
- Easy Checkout

QUESTIONS: Parts@Valleytoolmfg.com



Top Level Assembly

ITEM	DESCRIPTION	PART NUMBER	QTY
1	ASSEMBLY - FX36 - CUTTER DRUM	2640-RH-4	1
2	ASSEMBLY FX36 SHIELD WELDMENT	2643-RH-4	1
5	EX SPINDLE HOUSING ASSEMBLY WITH BEARINGS	06288	1
7	ASY FX36 RECUTTER BAR WITH HARDWARE	07648	1
9	ASY MOTOR GUARD LH FX36	07667	2
11	ASY 63CC PISTON MOTOR WITH PLUMBING FX36	07679	1
12	CHECK VALVE 3/4IN 5KSI FX36	07680	1
13	ASY MOTOR GUARD RH FX36	08837	1
14	DECAL FX36 DEFENDER	DC-248	2
18	DECAL READ BEFORE OPERATING 4X6	DC-220	1
20	TIE DOWN POINT	DC-232	4
22	INSPECT KNIVES TORQUE	DC-242	1
23	2 7/16 FLANGE BLK ROLLER BRG	EFR-B22439E	1

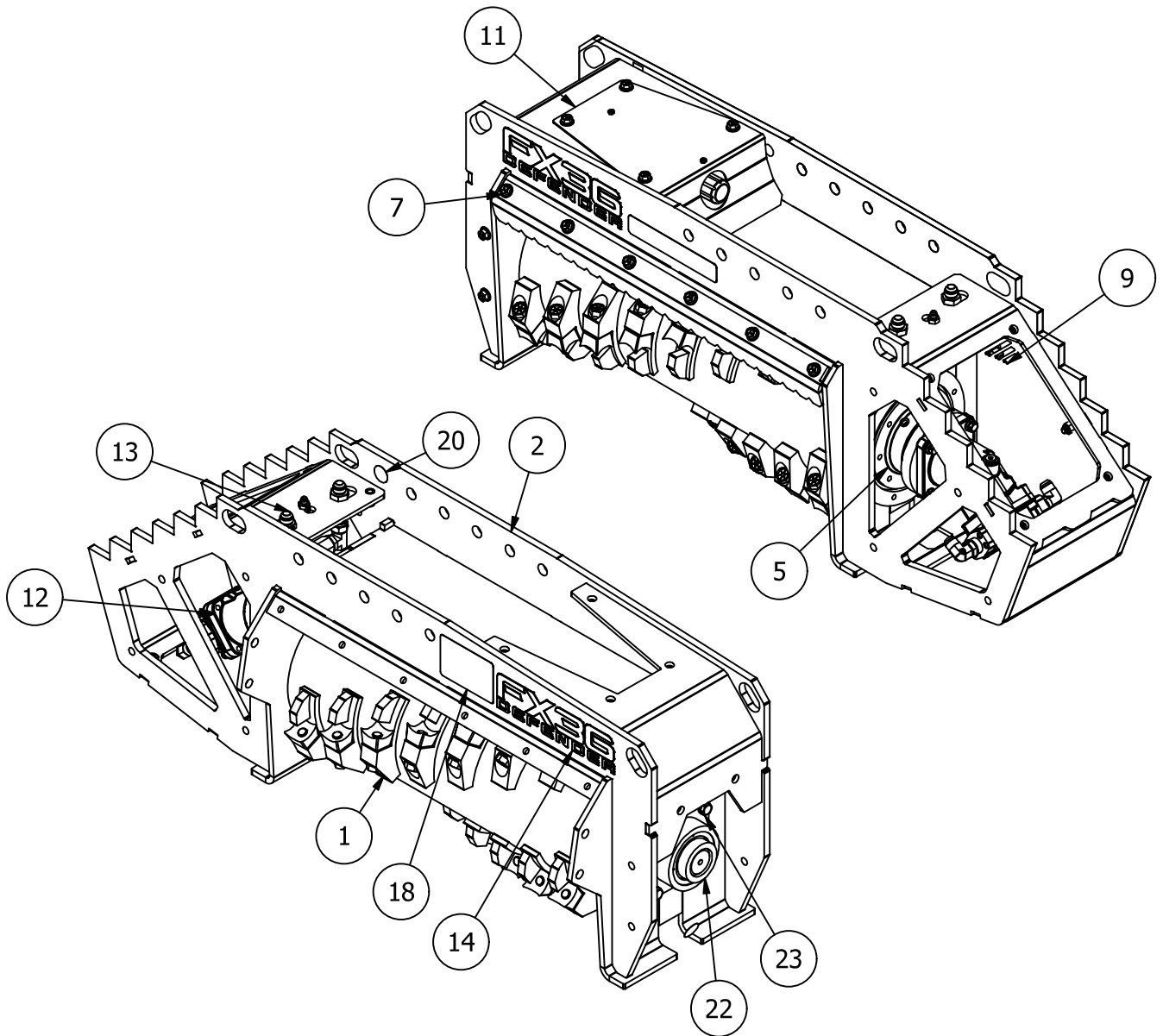

Motor Plumbing

ITEM	DESCRIPTION	PART NUMBER	QTY
1	1/2-13 UNC 1-3/4 Bolt	92865A718	4
2	1/2" Lock Washer		4
3	1/2" Washer (Not Shown)		4
4	HYD. PISTON MOTOR - 63CC SIDE PORTS	1929-62-12-12	2
5	1929-62-SAE Port Block - Code 62 (O-Ring Face)	6801-12-12-NWO-FG	2
6	6801-NWO-FG-MJ-MAORB 90° Elbow	6801-12-12-NWO-FG	2

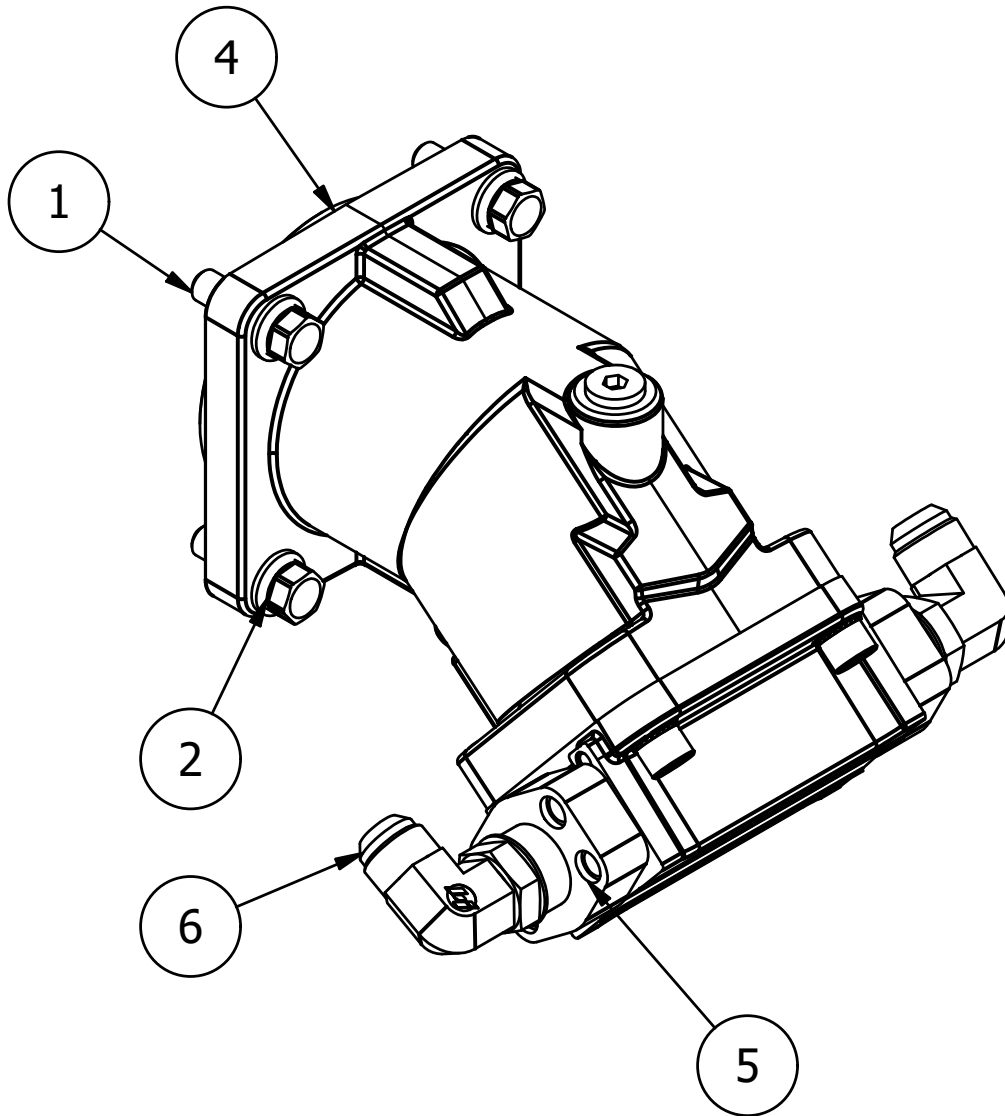

Tool Holder

ITEM	DESCRIPTION	PART NUMBER	QTY
1	TOOL HOLDER	2558-RH-3	1
2	QUADCO KNIFE	QH10110	1
3	CUT LIMITER	2556-RH-3	1
4	FHCS 3/4-16 X 2.5 GR8 YLZ	90409A211	1

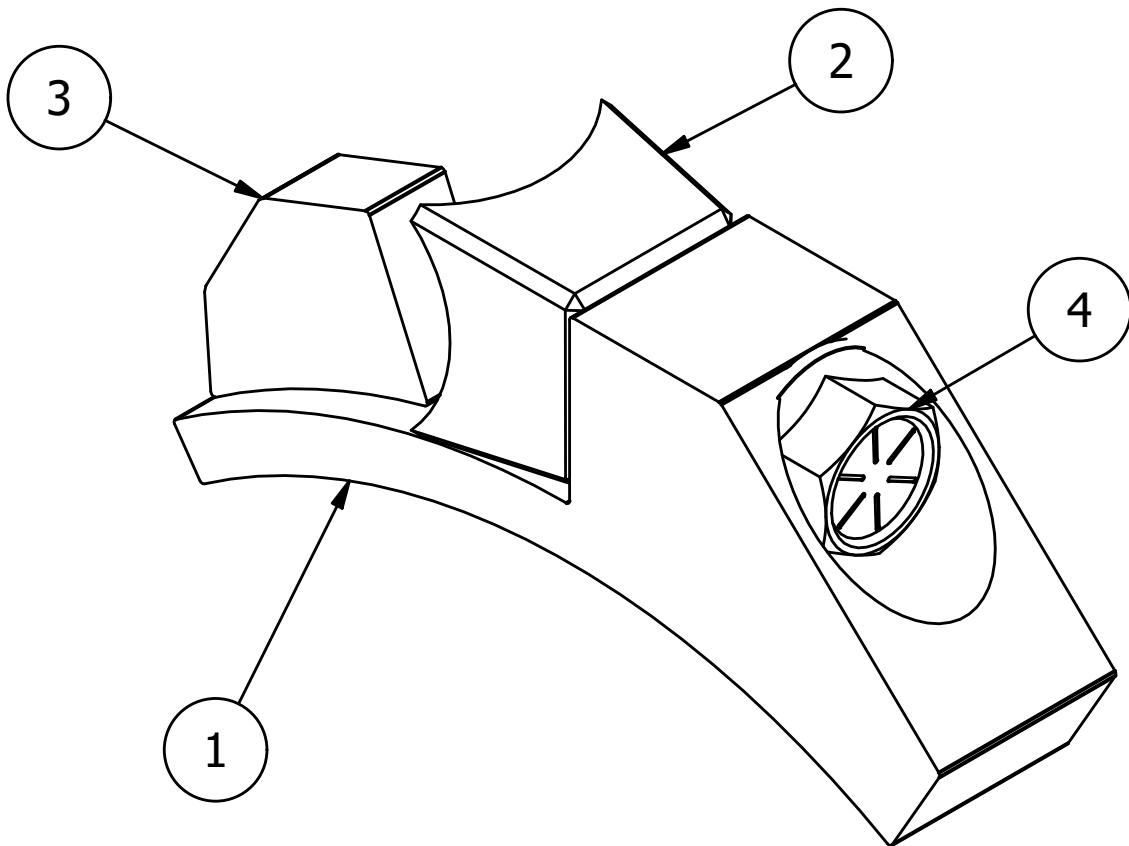

Cutter Drum

ITEM	DESCRIPTION	PART NUMBER	QTY
1	CUTTER DRUM - FX36	2777-RH-2	1
2	ASSEMBLY - TOOL STATION FX36	2551-RH-4	24
3	ASSEMBLY - DRIVE SPINDLE	2641-RH-4	1
4	ASY IDLE SPINDLE FX36	08826	1

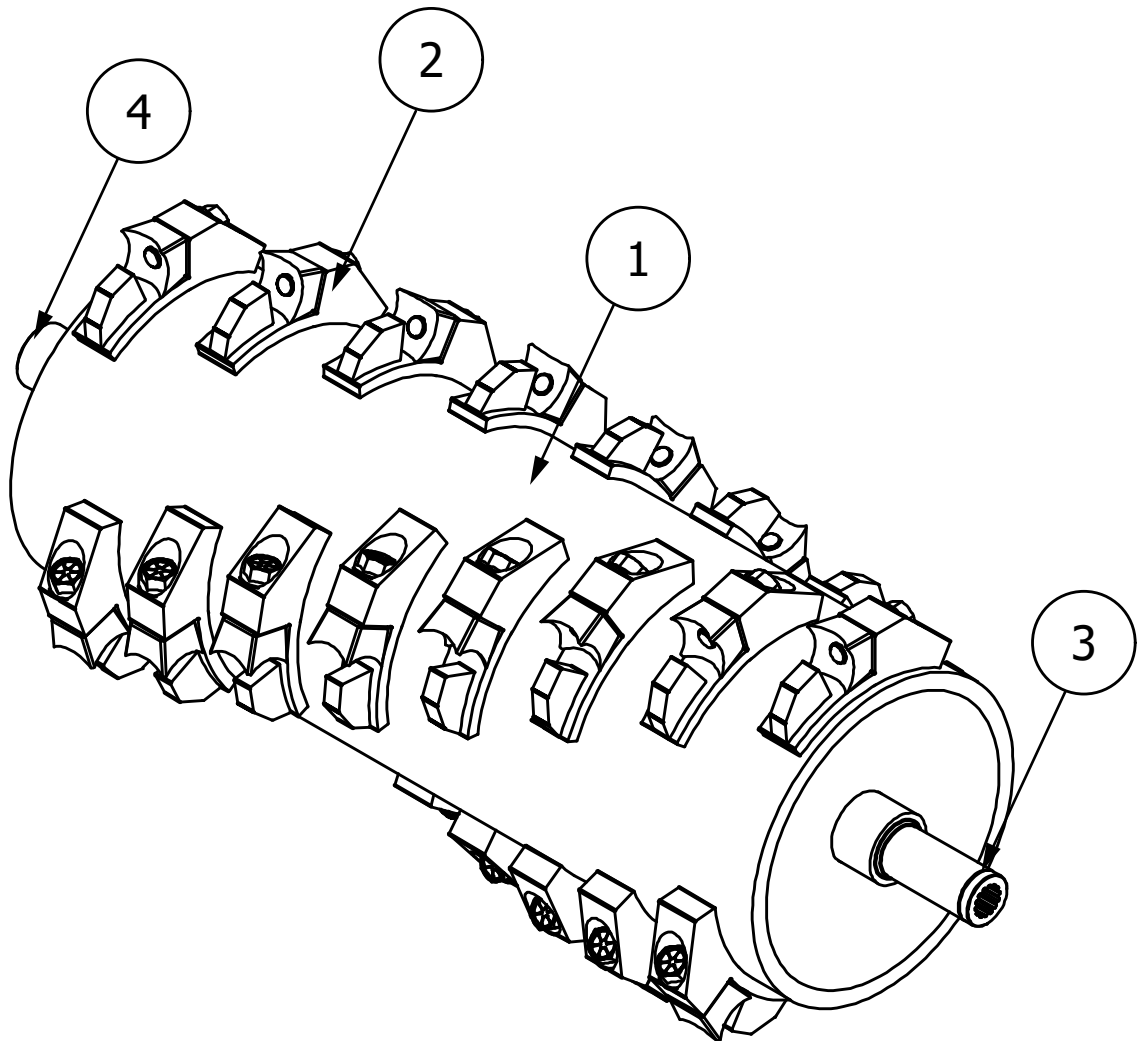

Recutter Door

ITEM	DESCRIPTION	PART NUMBER	QTY
1	ASY FX36 RECUTTER BAR WITH HARDWARE	07648	1
2	PLATE MOUNT FOR EJECTOR GUARD FX36	07642	2
3	CHANNEL STFNR EJ GUARD FX36	07672	1
4	PIECE 1 EJECTOR GUARD FX36	07643	1
5	WASHER 3/4 SAE CLZN	90126A036	4
6	HHCS 3/4-10 X 2 GR5	92865A843	4
7	NUT 3/4-10 GR5	95462A538	4

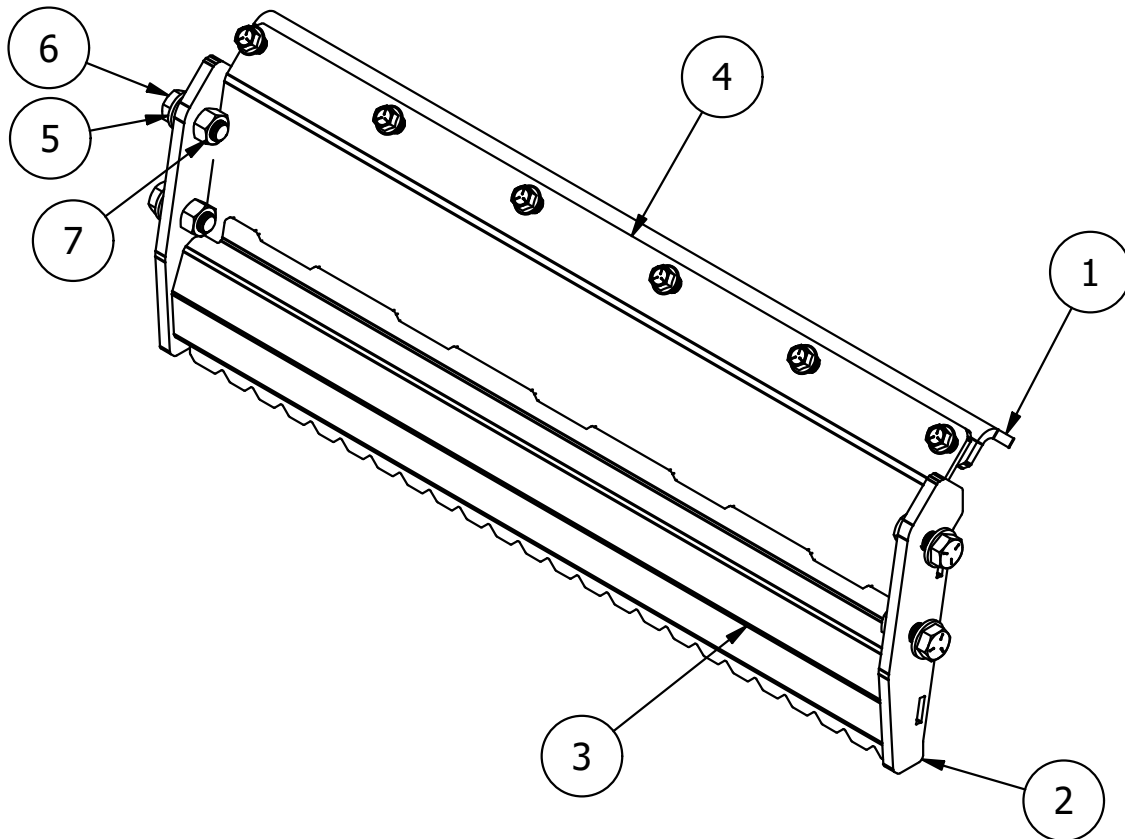

Guards

ITEM	DESCRIPTION	PART NUMBER	QTY
1	ASY EJECTOR GUARD V2 FX36	07641	1
2	GUARD REAR THUMB SADDLE UPPER FX36	07663	1
3	GUARD REAR LOWER FX36	07664	1

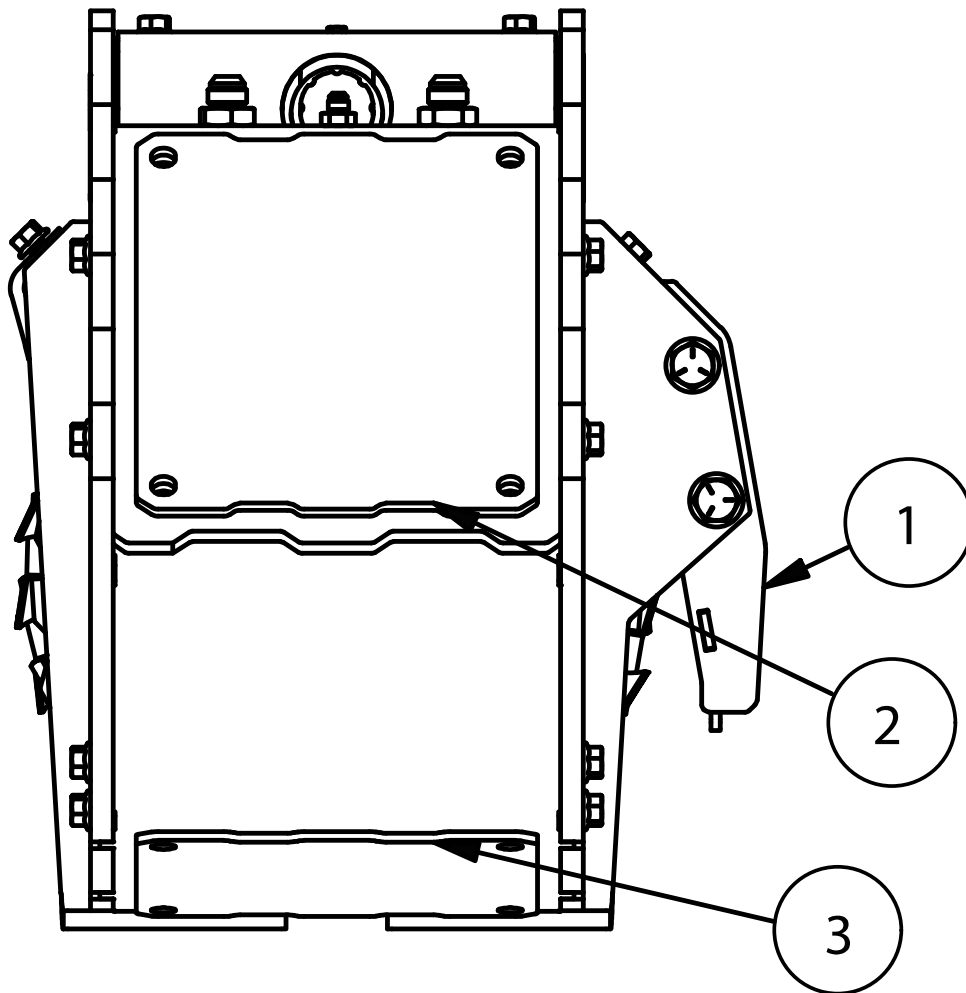

Decals

ITEM	DESCRIPTION	PART NUMBER	QTY
1	FX36 BRANDING DECAL	DC-248	2
2	BRUSHHOUND LOGO	DC-116	1
3	ROTATING CUTTER DRUM	DC-222	3
4	READ BEFORE OPERATING	DC-220	2
5	INSPECT KNIFE TORQUE	DC-242	1
6	KEEP GUARDS IN PLACE	DC-296	4
7	PROP 65 WARNING	DC-232	4
8	TIE DOWN	DC-234	2
9	GREASE 50 HOURS	DC-308	1
10	PRODUCT REGISTRATION QR CODE	DC-354	1

<p>1</p> 	<p>2</p> 	<p>3</p> 
<p>4</p> 	<p>5</p> 	<p>6</p> 
<p>7</p> 	<p>8</p> 	<p>9</p> 
<p>10</p> 		

FX36 Defender
Forestry Mulcher
Owners Manual
REV: 260926



FX36 DEFENDER OWNER'S MANUAL



VALLEY TOOL
MANUFACTURING COMPANY

PO Box 220 | 2507 Tully Road | Hughson, CA 95326 | 800-426-5615
www.valleytoolmfg.com